



Use and maintenance manual complete of  
**EC** conformity declaration

# LIFTING BRACKET WITH LIFTING PIN



Article numbers: **B01.35 - B02.45**

## INDEX

1. RISKS EVALUATION .....	3
2. SYMBOLS AND WARNINGS CLASSIFICATION .....	3
3. USE .....	4
4. HANDLING AND STORAGE .....	10
5. MAINTENANCE .....	11
EC CONFORMITY DECLARATION .....	12

## 1. RISKS EVALUATION

The matters of following pages refer to a classic use of lifting brackets and they can't forecast unspecified applications. For this reason each user must provide to his own risks evaluation and he must consider this manual as general reference support and as a summary of possible matters. To define the employ-procedures, to spread information and to check the compliance of these ones it's a duty and a responsibility of the user.









The lifting brackets have to be used as couplets for ropes and chains and they allow users to make on safety the following actions: LIFTING, HANDLING; the material, the production and the quality-check of all OMCR lifting pins comply with the Directive **2006/42/EC** requirements; all OMCR lifting elements have been tested with a static safety factor even to a minimum 1.5, all materials have been analyzed according to **UNI EN 10204**, samples of all materials have been subjected to tensile stress test according to **UNI EN 10002**.

### **WARNING**

***An improper or opposed use in reference to the prescriptions treated in this manual, deletes this EC conformity declaration and relieves OMCR from any responsibility.***

## 2. SYMBOLS AND WARNINGS CLASSIFICATION

According to ISO 3864-2, ANSI Z535.6, ANSI Z535.4 norms, in this manual are classified the following safety messages and symbols:

 <b>WARNING</b>	It indicates a hazardous situation which, if not avoided, could result in death or serious injury.
 <b>WARNING</b>	It indicates a hazardous situation which, if not avoided, could result in minor or moderate injury.
<b>NOTE</b>	It indicates advices on use or other especially helpful informations.
	It indicates general warning symbol.
	It indicates hazard of crushing consequent to an accidental fall or overturning of the load.
	It indicates hazard of crushing.
	It indicates musculoskeletal disorders for the handling of the loads.
	It indicates forbidden actions or uses.
	It indicates mandatory actions to avoid hazards.
	It indicates that it is forbidden to stop or to transit.

### 3. USE

#### 3.1

#### ⚠ WARNING



Each lifting, handling or overturning operations must be executed by qualified and instructed worker; the lifting, handling or turnover' officers must use individual guard equipment.

#### 3.2

#### ⚠ WARNING



Before each lifting, handling or overturning officers have to choose the most suitable sling to ensure a safe suspension with a correct load balance. A wrong sling method can modify the real capacity load of the ropes/chains and lifting accessories. In the following table you can verify the reduction of the nominal capacity load related to the sling angles in order to preserve the minimum safety factor.

#### NOTE

Refer to EN818-06 norm to define symmetric and asymmetric sling method: for asymmetric sling, the whole load should be supported by only two rope/chain wings.

#### 3.2.1 - LIFTING

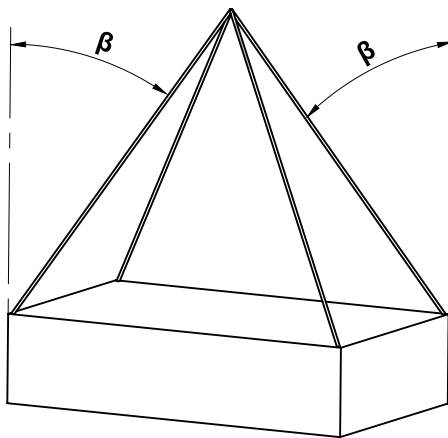

#### SYMMETRIC SLING EXAMPLE (RECOMMENDED CONDITION)

ANGLE	REDUCTION FACTOR OF THE NOMINAL CAPACITY LOAD
$0^\circ \leq \beta \leq 40^\circ$	1
$40^\circ < \beta \leq 50^\circ$	0.84
$50^\circ < \beta \leq 60^\circ$	0.65

**G** = Die load center

**β** = Rope angle from vertical

**NOTE:** lifting with  $\beta > 60^\circ$  is not provided

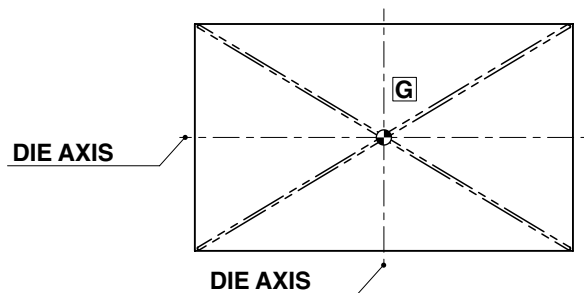

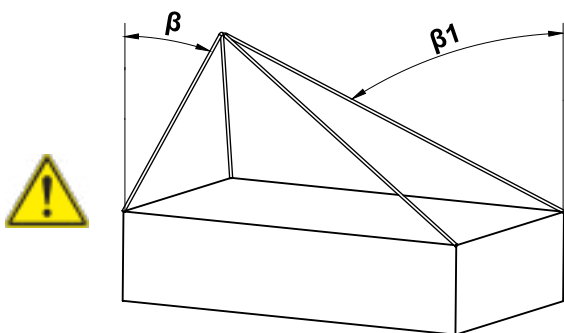

**ASYMMETRIC SLING EXAMPLE**  
( $\beta_1 > \beta$ )

**REDUCTION FACTOR OF THE NOMINAL CAPACITY LOAD**

0.5

**G** = Die load center

$\beta$  = Minimum rope angle from vertical

$\beta_1$  = Maximum rope angle from vertical

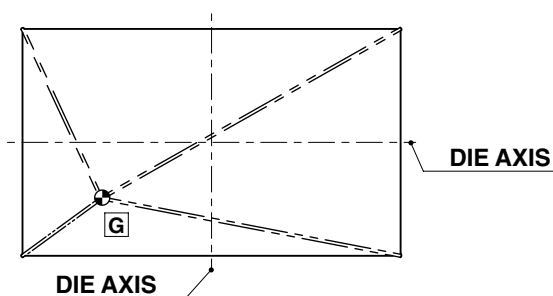

**WARNING**

*The missing respect of the prescriptions included in this manual may cause the accidental fall of the load.*

**3.2.2 - OVERTURNING**

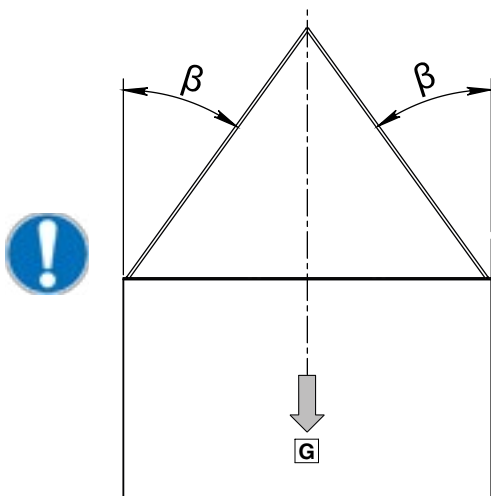

**SYMMETRIC SLING EXAMPLE**  
(RECOMMENDED CONDITION)

ANGLE	REDUCTION FACTOR OF THE NOMINAL CAPACITY LOAD
$0^\circ \leq \beta \leq 40^\circ$	1
$40^\circ < \beta \leq 50^\circ$	0.84
$50^\circ < \beta \leq 60^\circ$	0.65

**G** = Die load center

$\beta$  = Rope angle from vertical

**NOTE:** *overturning with  $\beta > 60^\circ$  is not provided*

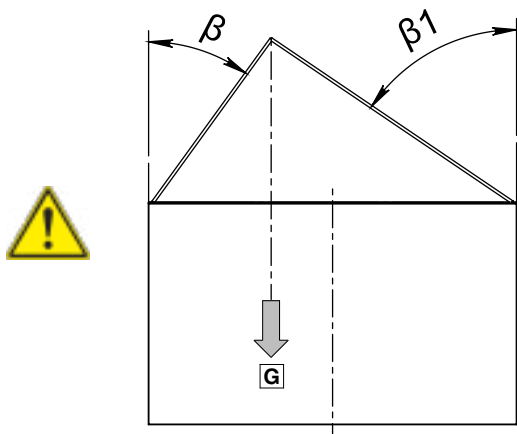

**ASYMMETRIC SLING EXAMPLE**  
( $\beta_1 > \beta$ )

ANGLE	REDUCTION FACTOR OF THE NOMINAL CAPACITY LOAD
$\beta < 15^\circ$	0.5
$\beta > 40^\circ$	
$\beta_1 - \beta > 15^\circ$	

**G** = Die load center

**$\beta$**  = Minimum rope angle from vertical

**$\beta_1$**  = Maximum rope angle from vertical

**WARNING**

*The missing respect of the prescriptions included in this manual may cause the accidental fall of the load.*

**3.2.3**

**WARNING**



*The die overturning is allowed only parallel with lifting pin axis.*

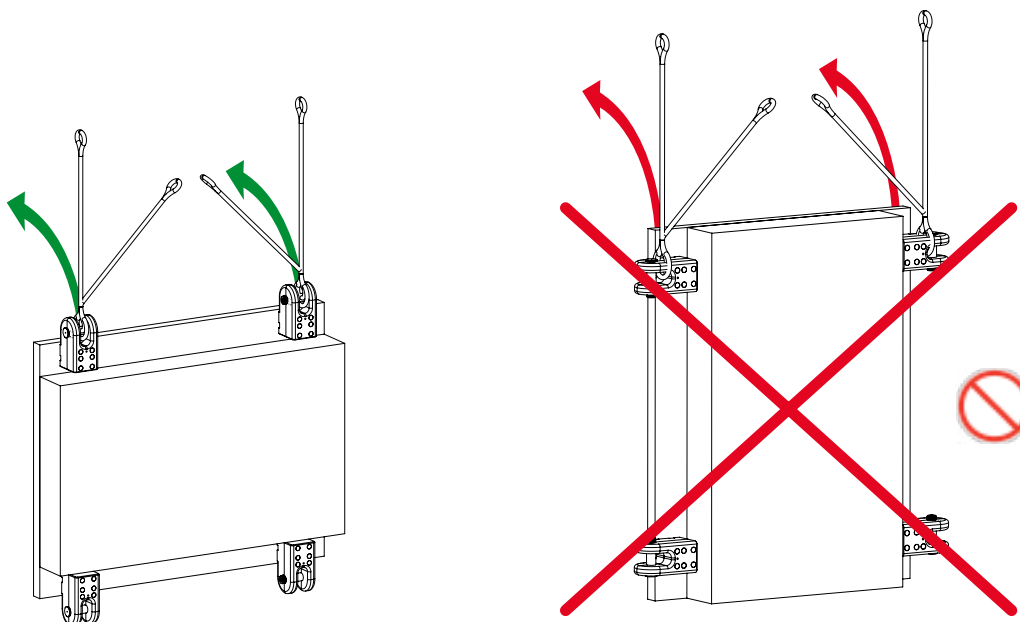

### 3.3

#### **⚠ WARNING**



At the moment of the use, check the correct screws clamping and the use of screws with the required lengths; in the following table are written down screws and clamping couples for the fixing of the lifting brackets; **it is recommended to use threadlocker LOCTITE 243 or lock washers. Absolutely ensure a minimum screws clamping of 1 x Ø screw. Example: for M36 screws use a minimum clamping of 36 mm.**

LIFTING BRACKET ART. NUM.	NR. SCREWS	SCREWS DIN 912 CL. 8.8	CLAMPING COUPLE [Nm]
B01.35.42500	6	M36x250	2481

#### **⚠ WARNING**

The missing respect of the prescriptions included in this manual may cause the accidental fall of the load.

### 3.4

#### **⚠ WARNING**



**B01.15. lifting brackets should be mounted on steel plates (minimum quality Fe510, S355) with keys. It is recommended to provide barriers to avoid the wrong pins insertion (see **Pic.1**).**

#### 3.4.1 - APPLICATION ON FLAT SURFACE

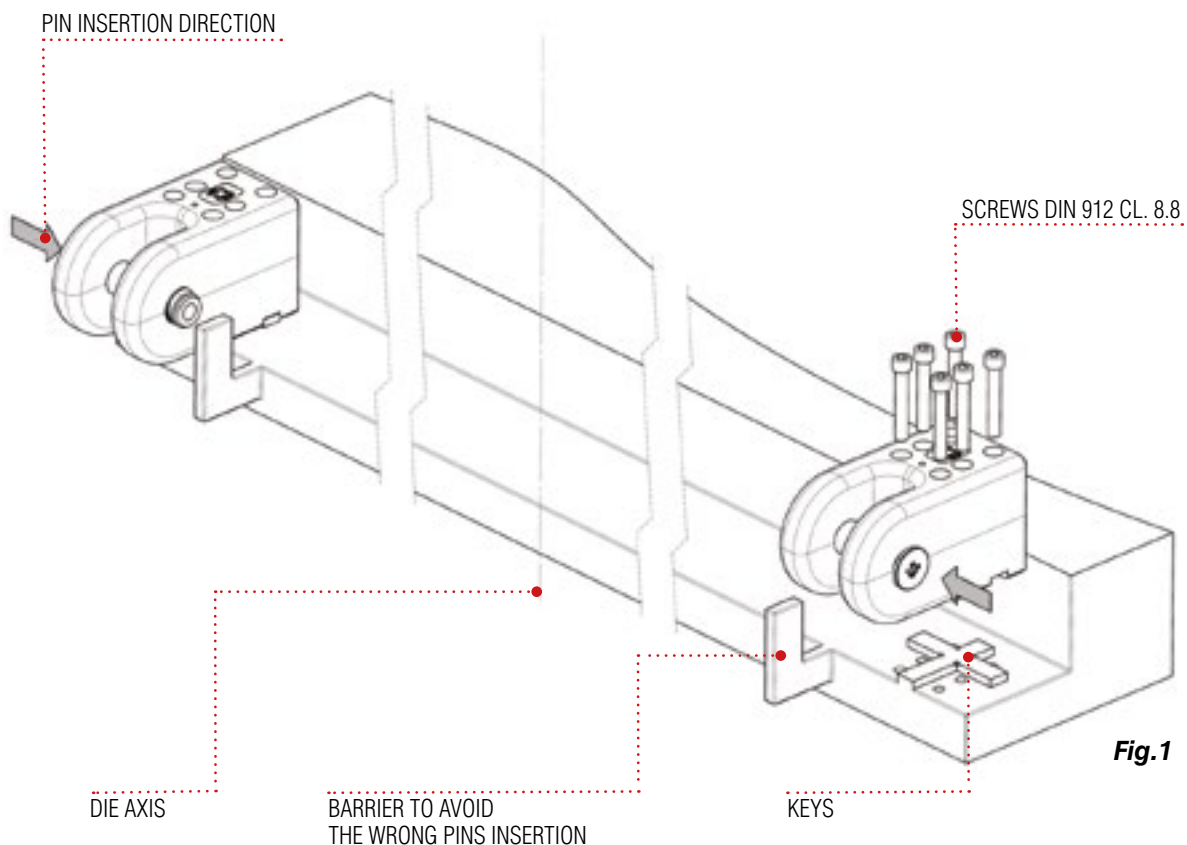

### 3.5

#### ⚠ WARNING



Before each lifting, handling or overturning of the die be sure about the correct insertion of the lifting pin that has to be **ABSOLUTELY** assembled **with the safety ring** positioned in direction of the die axis: after inserting it, be sure that the **safety ring** is misaligned in reference to the hole so that the pin accidental extraction is avoided; check the movement of the **safety ring** by verifying the eccentricity "E" in reference to the pin (see **Pic.2**).

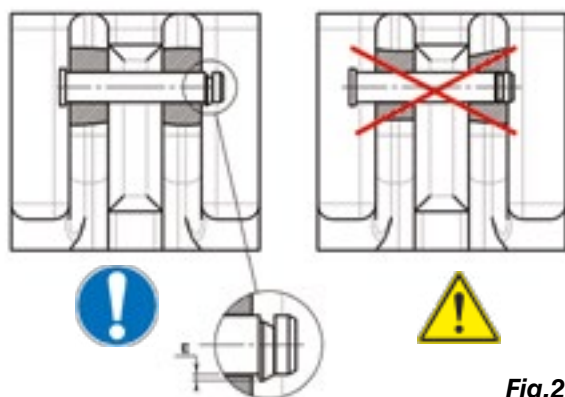

Fig.2

CODICE STAFFE	CODICE PERNI
B01.35.42500	B02.45.100

### 3.6

#### ⚠ WARNING



Before each lifting, handling or turnover check that the lifting brackets capacity load is in compliance with the die weight; the maximum capacity load, the work order number, the constructor label and the **EC conformity mark** are indelibly marked on the lifting pins and over the lifting brackets. **NOTE:** the work order numbers of lifting brackets and pins are not necessarily corresponding (see **Pic.3**).

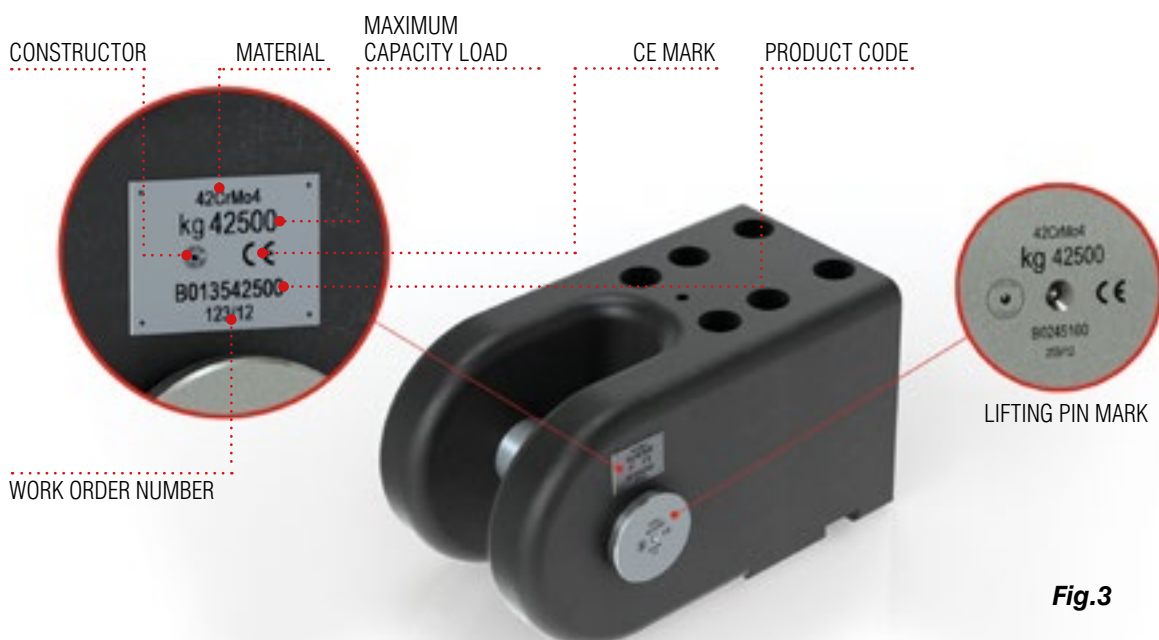

Fig.3



In case of lifting and handling, the lifting bracket capacity load should be at least **1/2** of the whole die weight. (upper half-die + lower half-die).

Example: die weight 85.000 kg - minimum lifting bracket capacity load:  $85.000 / 2 = 42.500$  kg

In case of overturning the max capacity load for each lifting bracket is the 60% of the nominal load.

Example: two 42.500 kg lifting bracket can overturn  $42.500 / 2 = 21.250$  kg

### 3.7

#### WARNING



Before each lifting, handling or overturning of the die, check that the chosen sling system (rope/chain, hook, etc.) doesn't present any defect or deformation to make it unsafe; **otherwise replace immediately the damaged parts.**

### 3.8

#### WARNING



To prevent the pin accidental extraction, don't make lifting, handling or overturning with sling angle bigger than 90° from the horizontal level (see **Pic.4**).

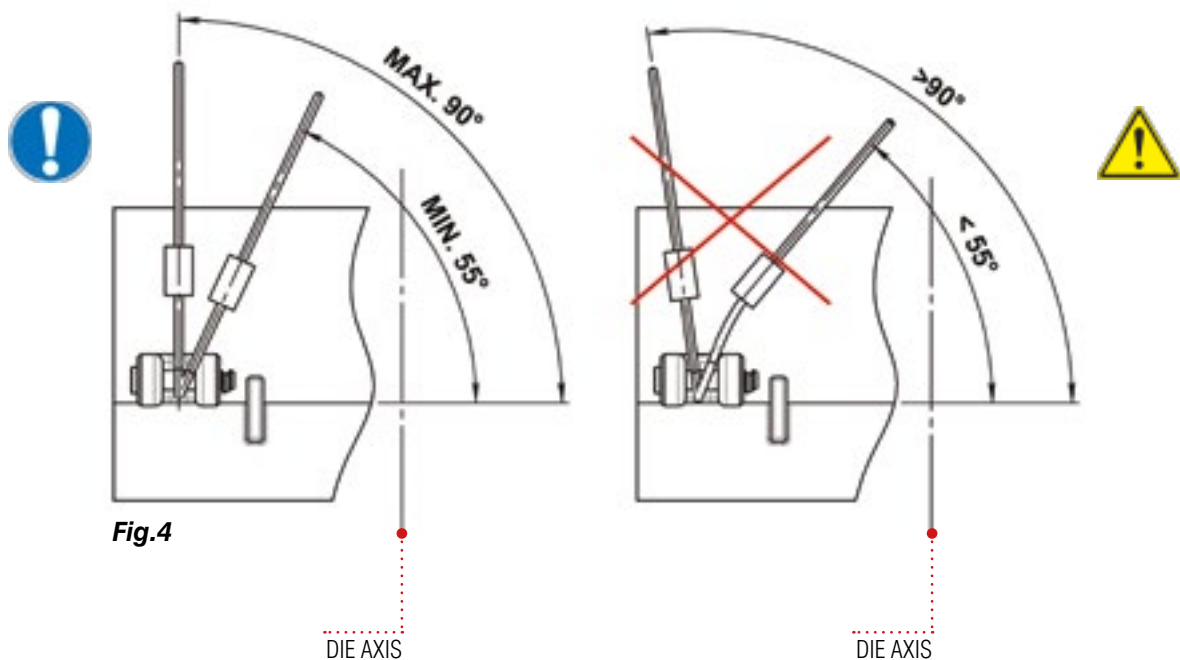

**Fig.4**

**Pic.4**

### 3.10

#### **WARNING**



Don't stand or transit nearby the load during lifting, handling or overturning operations (see **Pic.5**). In case of accidental release of the load there may be risks of injury.



**Pic.5**

## 4. HANDLING AND STORAGE

### 4.1

#### **WARNING**



In the following table are written OMCR B01.35. lifting brackets weights; **the lifting brackets must be handled in compliance with the current norms concerning the movement by hand of the loads** (see **Pic.6**).

LIFTING BRACKET ART. NUM.	WEIGHT (kg) <i>lifting pin included</i>
B01.35.42500	

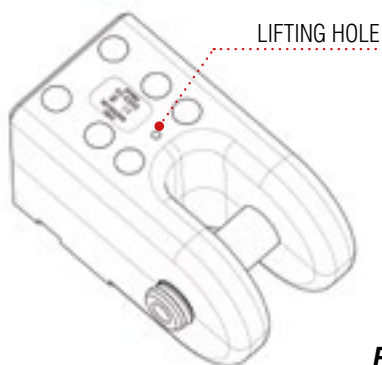

**Pic.6**

**4.2** If not used the lifting brackets must be stored far from wet and preserved from oxidation by applying protective oil.

### 4.2.1

#### **WARNING**



**At the moment of the assembling, carefully clean the contact surfaces between lifting brackets and steel plates.**

The presence of oil or dirt on the contact surface between the lifting bracket and the mold holder plate may compromise the correct functioning of the lifting bracket

## 5. MAINTENANCE

**5.1** Once every 6 months check the presence of anomalies or oxidations by visual tests: in that case restore or replace the lifting brackets or pins.

**5.2** Once every 12 months check the cilindricity of the pins to notice eventual permanent deformations (see **Pic.7**): in case of deformation over 0,25 mm replace the pins.

**5.3** Once every 6 months check the correct clamping couple of the screws according to values indicated on the table.

**5.4** In case of unexpected failure of lifting ropes/chains with a consequent overload on the lifting pins, check their cilindricity (see **Pic.7**) to notice eventual deformations; in case of deformation over 0,25 mm replace the pins; substitute the fixing screws and check the correct clamping couple of the screws according to values indicated on the table.

**5.5** In case of accidental impacts on the lifting elements during the lifting, handling and overturning operations, check the cilindricity of the pins (see **Pic.7**); in case of deformation over 0,25 mm replace the pins; check eventual deformations on the lifting brackets and, if noticed, replace them; substitute the fixing screws and check the correct clamping couple of the screws according to values indicated on the table.

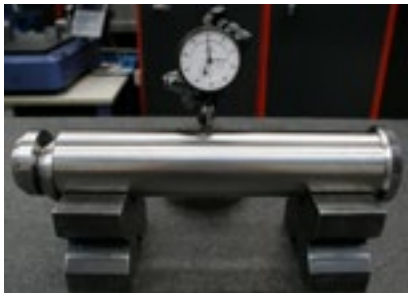

**Pic.7**

## EC CONFORMITY DECLARATION

(Directive 2006/42/CE)

OMCR S.r.l. seated in Via Quarantelli, 8 – 10077 S.Maurizio C.se – (Torino-Italy) through its legal representative manager, declares that:

### **LIFTING BRACKET WITH LIFTING PIN (VDI3366)**

#### **Codice articolo: B01.15 – B02.10**

Have a work order number indelibly marked on every model, it is possible to find out the documents filed in the Technical Office, to identify each manufacturing and inspective feature of the product. All the quality and safety procedures are arranged by Mr. Bertorello, responsible of the “technical file,” acting in OMCR, Via Quarantelli 8, 10077 San Maurizio C.se. These procedures have been exactly issued to allow OMCR mark with **EC symbol** to ensure that these products:



- are in compliance with the established conditions from Directive 2006/42/EC of 9.6.2006
- are tested and controlled, to be suitable also with the harmonized and national UNI Norms, the European Directives and the italian safety dispositions on work.

*Before using lifting pins and lifting brackets, please read carefully the “Use and maintenance manual”.*

*An improper or opposed use in reference to the prescriptions treated in this manual, deletes this **EC conformity** declaration and relieves OMCR from any responsibility.*

*Translation of the original Use and Maintenance Manual and Conformity Declaration.*

*In case of doubts or misunderstandings, the Italian version is decisive.*

**OMCR S.r.l.**  
The legal representative  
Domenico Zentilin





Manuale di Uso e Manutenzione completo di dichiarazione **CE** di conformità.

# STAFFA DI SOLLEVAMENTO COMPLETA DI PERNO



Codice Articolo: **B01.35 - B02.45**

## INDICE

1. VALUTAZIONE DEI RISCHI . . . . .	15
2. SIMBOLOGIE E CLASSIFICAZIONE DELLE AVVERTENZE . . . . .	15
3. USO . . . . .	16
4. MOVIMENTAZIONE E STOCCAGGIO . . . . .	22
5. MANUTENZIONE . . . . .	23
DICHIARAZIONE CE DI CONFORMITÀ . . . . .	24

## 1. VALUTAZIONE DEI RISCHI









I contenuti delle pagine che seguono sono riferiti agli usi classici delle staffe di sollevamento e non possono prevedere impieghi non specifici. Per tale ragione ciascun utilizzatore deve provvedere ad una propria valutazione dei rischi e tenere conto di questo manuale come supporto di riferimento generale considerando la necessità di sintesi nel trattare gli argomenti. Rimane compito e responsabilità dell'utilizzatore definire per gli addetti le procedure di impiego per le operazioni da eseguire, darne informazione e verificarne l'osservanza. Le staffe di sollevamento servono da aggancio per funi o catene e permettono di effettuare in sicurezza operazioni di: **SOLLEVAMENTO e MOVIMENTAZIONE**; il materiale, la produzione e il collaudo di tutte le staffe di sollevamento OMCR sono conformi alle richieste della direttiva **2006/42/CE**; tutti gli elementi di sollevamento OMCR sono verificati con un coefficiente di prova statica pari a minimo 1.5, su tutti i materiali sono effettuate analisi secondo la **UNI EN 10204**, a campione vengono effettuate prove a trazione convenzionale conformi alla **UNI EN 10002**.

### **AVVERTENZA**

***Prima dell'utilizzo delle staffe di sollevamento leggere attentamente il manuale di uso e manutenzione. Un uso improprio o contrario, a quanto prescritto nel presente manuale, solleva l'OMCR da ogni responsabilità in merito alla sicurezza degli elementi citati.***

## 2. SIMBOLOGIE E CLASSIFICAZIONE DELLE AVVERTENZE

Secondo le normative ISO 3864-2, ANSI Z535.6, ANSIZ535.4, nel presente manuale sono stati classificati i seguenti messaggi di sicurezza e i simboli:

 <b>ATTENZIONE</b>	Indica una situazione potenzialmente pericolosa, che se non evitata, può provocare gravi infortuni o morte.
 <b>ATTENZIONE</b>	Indica una situazione potenzialmente pericolosa, che se non evitata, può provocare lesioni lievi o moderate
<b>NOTE</b>	Indica suggerimenti o altre informazioni di particolare importanza.
	Indica un pericolo generico.
	Indica un rischio di schiacciamento conseguente la caduta o il ribaltamento del carico.
	Indica un rischio di cesoiamento conseguente la caduta o il ribaltamento del carico.
	Indica un rischio muscolo-scheletrico per la movimentazione manuale dei carichi.
	Indica operazioni o modo d'uso proibiti.
	Indica azioni da effettuare per evitare rischi.
	Indica il divieto di sostare o transitare.

### 3. USO

#### 3.1

#### ⚠ AVVERTENZA



Ogni operazione di sollevamento e movimentazione deve essere eseguita da personale qualificato ed opportunamente formato; gli addetti al sollevamento e movimentazione devono far uso dei mezzi di protezione individuale in loro dotazione.

#### 3.2

#### ⚠ AVVERTENZA



Prima di ogni sollevamento o movimentazione gli addetti devono scegliere la modalità di imbracatura più idonea per garantire una sospensione sicura con un corretto equilibrio del carico. L'effettiva portata delle funi / catene e degli accessori di sollevamento può essere alterata da una imbracatura scorretta. Nelle tabelle seguenti si può valutare la riduzione della portata nominale in funzione dell'angolo dell'imbracatura al fine di mantenere costante il fattore di sicurezza.

#### NOTE

Per la definizione delle imbracature simmetriche e asimmetriche fare riferimento alla norma EN818-06: in caso di imbracature asimmetriche, si considera che il peso da sollevare sia sopportato da due soli bracci di fune/catena.

#### 3.2.1 - SOLLEVAMENTO

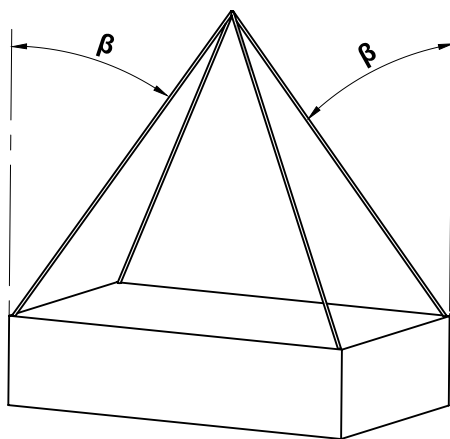

#### ESEMPIO DI IMBRACATURE SIMMETRICHE (CONDIZIONE CONSIGLIATA)

ANGOLO	FATTORE DI RIDUZIONE DELLA PORTATA DELLA STAFFA
$0^\circ \leq \beta \leq 40^\circ$	1
$40^\circ < \beta \leq 50^\circ$	0.84
$50^\circ < \beta \leq 60^\circ$	0.65

**G** = Baricentro stampo

**β** = Angolo funi dalla verticale

**NOTA:** non è previsto il sollevamento con  $\beta > 60^\circ$

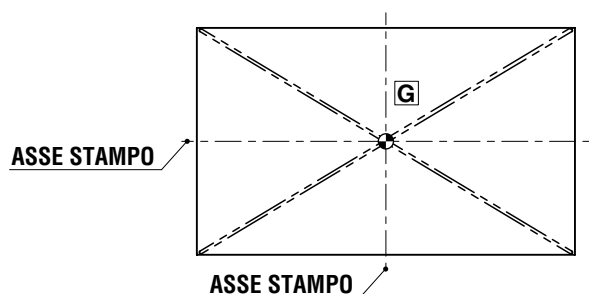



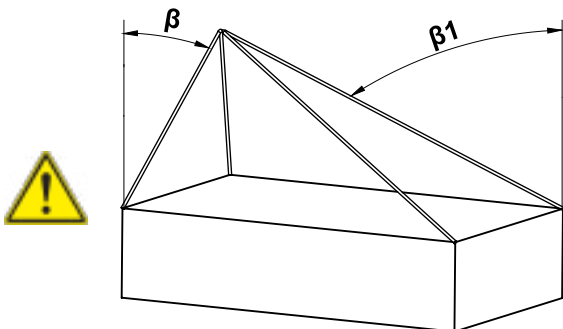

**ESEMPIO DI IMBRACATURE ASIMMETRICHE**

**FATTORE DI RIDUZIONE DELLA PORTATA DELLA STAFFA**

0.5

**G** = Baricentro stampo

**β** = Angolo funi minimo dalla verticale

**β1** = Angolo funi massimo dalla verticale

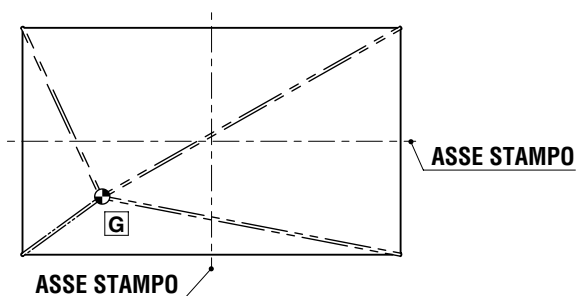

**AVVERTENZA**

*Il mancato rispetto delle prescrizioni contenute nel presente manuale può provocare il rischio di caduta accidentale del carico.*

**3.2.2 - RIBALTAMENTO**

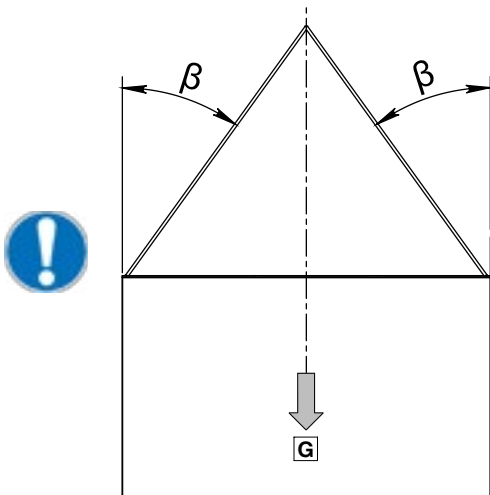

**ESEMPIO DI IMBRACATURE SIMMETRICHE (CONDIZIONE CONSIGLIATA)**

ANGOLO	FATTORE DI RIDUZIONE DELLA PORTATA DELLA STAFFA
$0^\circ \leq \beta \leq 40^\circ$	1
$40^\circ < \beta \leq 50^\circ$	0.84
$50^\circ < \beta \leq 60^\circ$	0.65

**G** = Baricentro stampo

**β** = Angolo funi dalla verticale

**NOTA:** non è previsto il ribaltamento con  $\beta > 60^\circ$

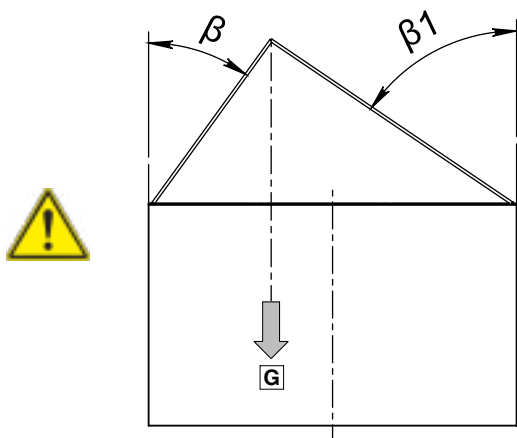

**ESEMPIO DI IMBRACATURE ASIMMETRICHE**  
( $\beta_1 > \beta$ )

ANGOLO	FATTORE DI RIDUZIONE DELLA PORTATA DELLA STAFFA
$\beta < 15^\circ$	0.5
$\beta > 40^\circ$	
$\beta_1 - \beta > 15^\circ$	

**G** = Baricentro stampo

**$\beta$**  = Angolo funi minimo dalla verticale

**$\beta_1$**  = Angolo funi massimo dalla verticale

**AVVERTENZA**

*Il mancato rispetto delle prescrizioni contenute nel presente manuale può provocare il rischio di caduta accidentale del carico.*

**3.2.3**

**AVVERTENZA**



*Il ribaltamento dello stampo può essere eseguito solo parallelamente all'asse del perno di sollevamento*

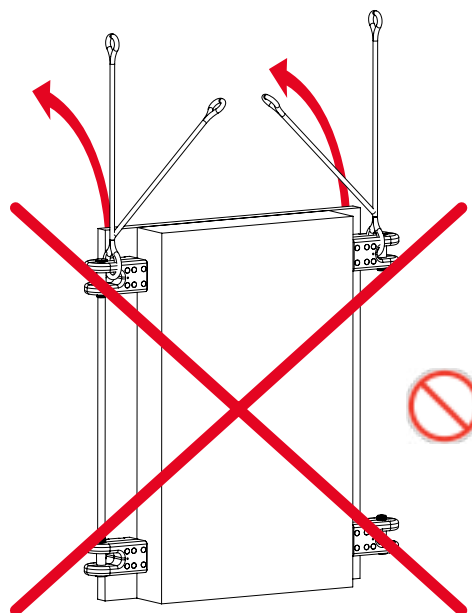
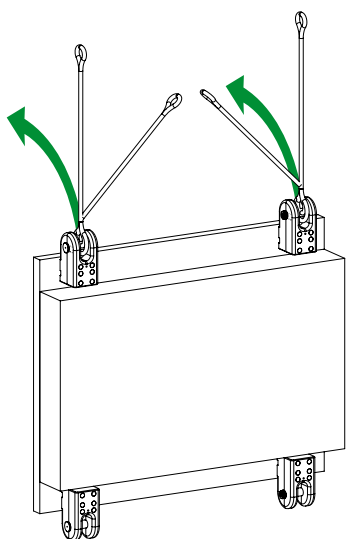

### 3.3

#### ⚠ AVVERTENZA



Al momento della messa in opera verificare la corretta chiusura delle viti; nella tabella seguente sono riportate le viti e le coppie di chiusura per il fissaggio delle staffe di sollevamento; **si consiglia di usare frenafilietti LOCTITE 243 o rondelle antisvitamento. Garantire tassativamente la presa filetto minima di 1 x Ø vite.**  
**ES: Per viti M36 presa filetto minima 36 mm**

ART.-NUM. STAFFA	NR. VITI	VITE DIN 912 CL. 8.8	COPPIA DI SERRAGGIO [Nm]
B01.35.42500	6	M36	2481

#### ⚠ AVVERTENZA

**Il mancato rispetto delle prescrizioni contenute nel presente manuale può provocare il rischio di caduta accidentale del carico.**

### 3.4

#### ⚠ AVVERTENZA



Le staffe B01.35. devono essere montate su piastre in acciaio (**qualità minima Fe510, S355**) con chiavette riportate o integrali ricavate nello stampo; si consiglia l'uso di barriere per impedire l'inserimento scorretto dei perni (vedi **Fig.1**).

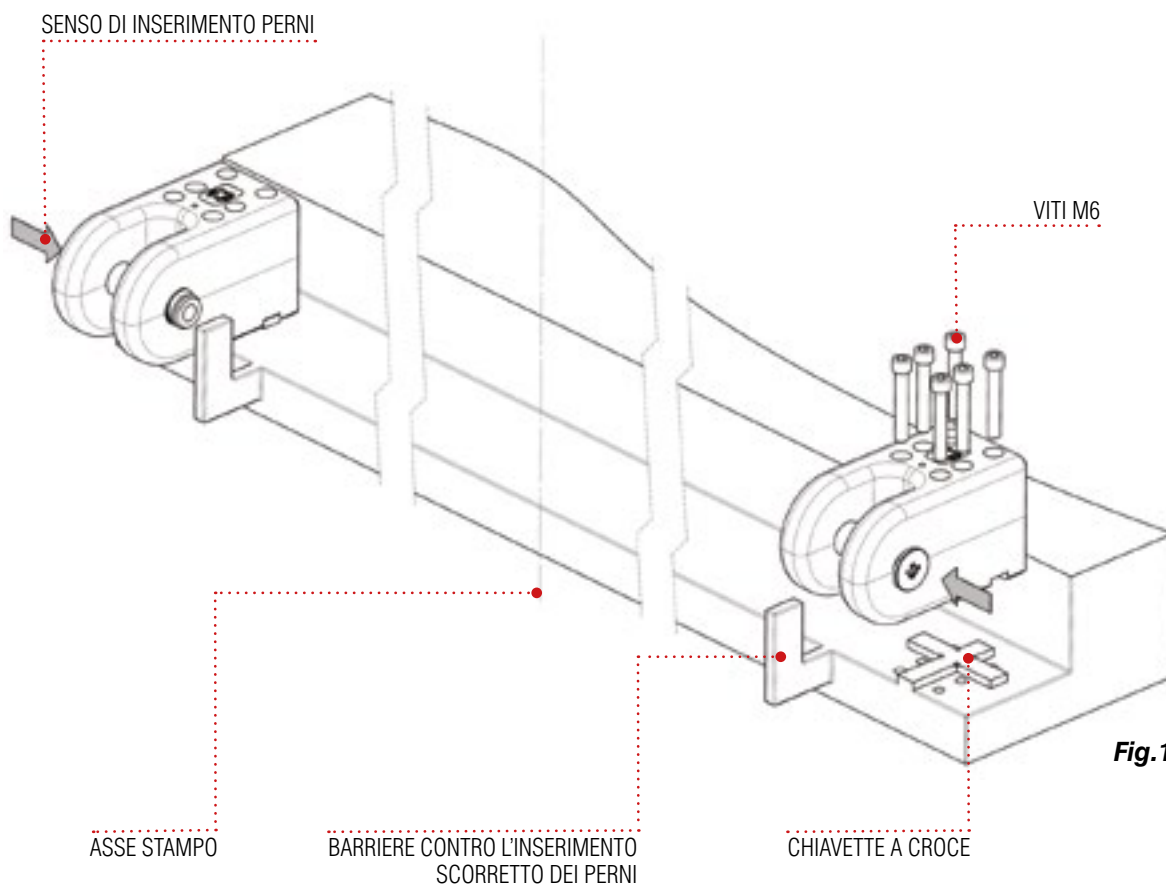

**Fig.1**

### 3.5

#### ⚠ AVVERTENZA



Prima di ogni sollevamento / movimentazione / ribaltamento dello stampo assicurarsi del corretto inserimento del perno di sollevamento che deve **TASSATIVAMENTE** essere montato con l'**anello di sicurezza** rivolto verso l'asse dello stampo: dopo averlo inserito accertarsi che l'**anello di sicurezza** sia disassato rispetto al foro e impedisca lo sfilamento del perno; verificare il movimento dell'**anello di sicurezza** verificando l'eccentricità "E" rispetto al perno (vedi Fig.2)

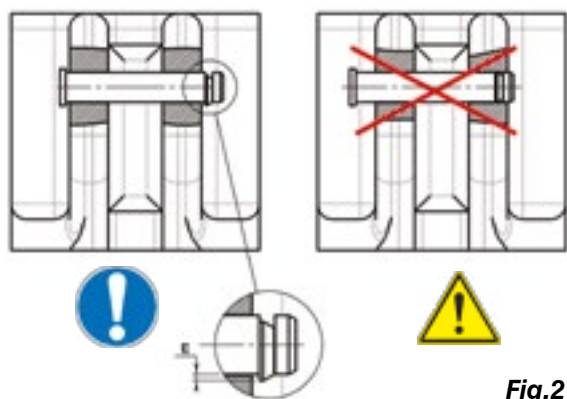

Fig.2

CODICE STAFFE	CODICE PERNI
B01.35.42500	B02.45.100

### 3.6

#### ⚠ AVVERTENZA



Prima di ogni sollevamento / movimentazione / ribaltamento verificare che la portata delle staffe di sollevamento sia conforme al peso dello stampo (**riportato su apposite targhette**); la portata massima, la commessa di fabbricazione, il logo del costruttore, il marchio di conformità CE, il codice prodotto e il materiale sono marcati in modo indelebile sulla staffa e sul perno di sollevamento. **NOTA:** non vi è necessariamente corrispondenza tra le commesse di fabbricazione di staffe di sollevamento e perni.



Fig.3

La portata della staffa di sollevamento non deve assolutamente essere inferiore ad **1/2** del peso totale dello stampo (semistampo superiore + semistampo inferiore) nel caso di sollevamento e movimentazione.

es: Peso stampo 85000 kg

Portata minima della staffa :  $85000/2=42500\text{kg}$

La portata della staffa di sollevamento non deve assolutamente essere inferiore ad **1/2** del peso del semistampo nel caso di ribaltamento.

### 3.7

#### AVVERTENZA



Prima di ogni sollevamento / movimentazione / ribaltamento dello stampo verificare che l'imbracatura scelta (funi / catena, ganci, redance, ecc.) non presenti difetti o malformazioni tali da pregiudicarne l'affidabilità; nel caso **eliminare immediatamente le parti difettose**.

### 3.8

#### AVVERTENZA



Non effettuare sollevamento / movimentazione con imbracature che formino angoli superiori a  $90^\circ$  rispetto all'orizzontale, in caso contrario si può verificare lo sfilamento del perno con rischio di caduta del carico (vedi **Fig.4**).

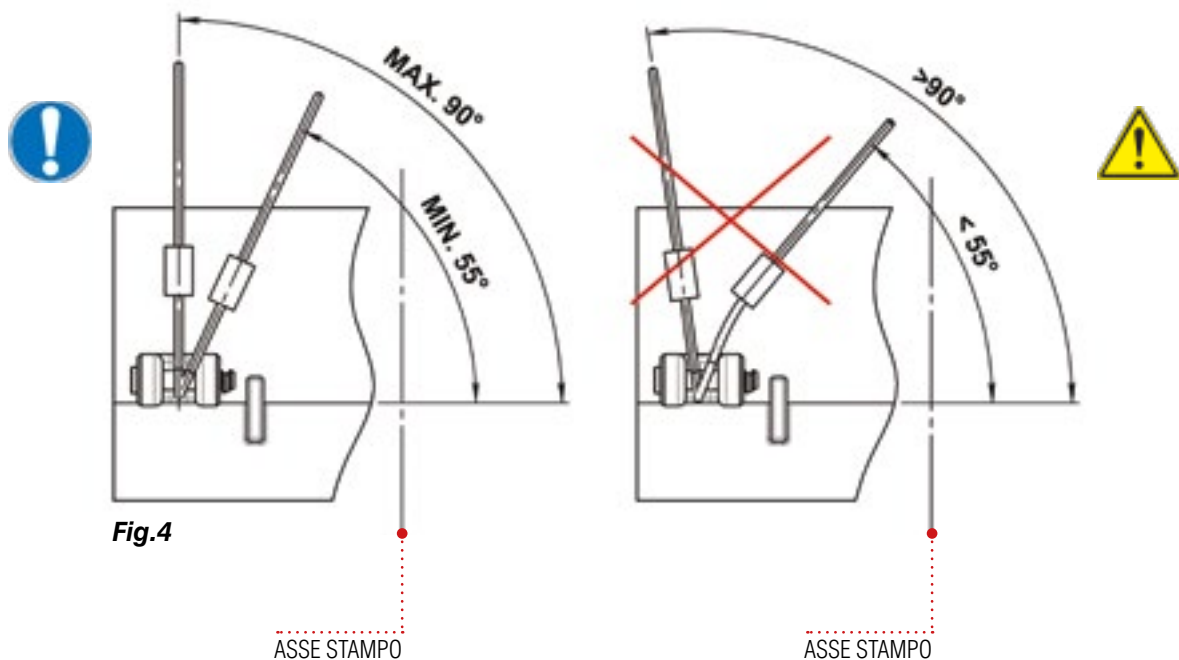

Fig.4

Fig.4

### 3.9

#### **AVVERTENZA**



Prima di ogni sollevamento / movimentazione dello stampo assicurarsi che:

- le funi / catene siano assicurate in modo corretto;
- le funi / catene non siano a contatto di bordi taglienti;
- le funi / catene non siano agganciate in spigoli dello stampo.

### 3.10

#### **AVVERTENZA**



Non sostare o transitare nelle vicinanze del carico durante le operazioni di sollevamento, movimentazione o ribaltamento (vedi Fig.5).



**Fig.5**

## 4. MOVIMENTAZIONE E STOCCAGGIO

### 4.1

#### **AVVERTENZA**



Di seguito sono indicati i pesi delle staffe OMCR cod. B01.35; **le staffe devono essere movimentate in conformità alle vigenti norme relative alla movimentazione manuale dei carichi, utilizzando l'apposito foro di sollevamento** (vedi Fig.6).

<b>CODICE STAFFE</b>	<b>PESO (kg)</b> <i>completa di perno</i>
B01.24.08000	24
B01.24.12500	50,5

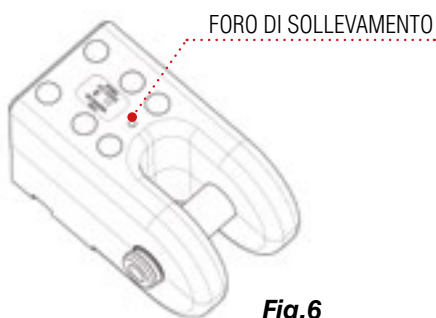

**Fig.6**

**4.2** Le staffe di sollevamento, se non utilizzate, devono essere stoccate in luogo riparato dall'umidità e protette dall'ossidazione applicando olio protettivo.

## 5. MANUTENZIONE

**5.1** Effettuare ogni 6 mesi controlli visivi per verificare la presenza di anomalie visibili o insorgenze di ossidazione: nel caso ripristinare o sostituire le staffe interessate.

**5.2** Effettuare almeno ogni 12 mesi una verifica di cilindricità sui perni per verificare eventuali deformazioni permanenti (**Fig.7**): nel caso di errori superiori a 0.25 mm sostituire i perni interessati.

**5.3** Effettuare ogni 6 mesi controlli sulla corretta chiusura delle viti di fissaggio secondo la tabella riportata nel manuale.

**5.4** In caso si verificassero cedimenti improvvisi di funi / catene di sollevamento con conseguente sovraccarico su staffe e perni di sollevamento, sottoporre questi a controllo di cilindricità (vedi **Fig.7**) per verificare eventuali deformazioni; nel caso di errori superiori a 0.25 mm sostituire i perni interessati; sostituire le viti di fissaggio e verificare la corretta chiusura secondo la tabella riportata nel manuale.

**5.5** In caso di urti accidentali nelle zone di imbracatura durante le operazioni di sollevamento movimentazione e ribaltamento, sottoporre i perni di sollevamento a controllo di cilindricità per verificare eventuali deformazioni; nel caso di errori superiori a 0.25 mm (vedi **Fig.7**) sostituire i perni interessati; sottoporre le staffe di sollevamento a controllo visivo per verificare eventuali deformazioni e nel caso sostituirle; sostituire le viti di fissaggio e verificare la corretta chiusura secondo la tabella riportata nel manuale.

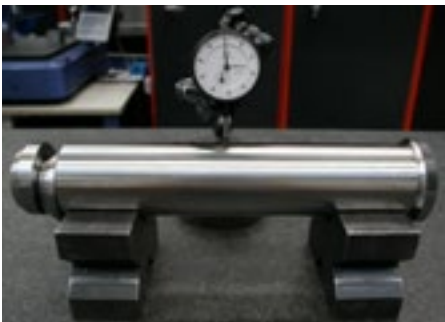

**Fig.7**

# DICHIARAZIONE **CE** DI CONFORMITÀ

(Direttiva Macchine 2006/42/CE)

L' OMCR S.r.l. con sede in Via Quarantelli, 8 – 10077 S.Maurizio C.se – (Torino-Italia) nella persona del suo legale rappresentante, dichiara che, le:

## **STAFFA DI SOLLEVAMENTO COMPLETA DI PERNO**

### **Codice articolo: B01.35 – B02.45**

hanno un numero di commessa di fabbricazione marcato in modo indelebile su ogni singolo esemplare, dal quale in ogni momento, si può risalire alla documentazione archiviata presso l'Ufficio Tecnico e così identificare ogni caratteristica ed elemento di produzione e collaudo.

Tutte le procedure di qualità e sicurezza predisposte dal Sig. Bertorello, responsabile del "Fascicolo tecnico", operante nella sede dell'OMCR, in Via Quarantelli, 8 10077 San Maurizio C.se, sono state correttamente eseguite e ciò ha permesso la stampigliatura del simbolo **CE** per garantire che tali particolari:



- sono conformi alle condizioni stabilite dalla Direttiva Macchine 2006/42/CE del 9.6.2006
- Sono state oggetto di controlli e verifiche per ritenere tali prodotti conformi anche per le norme UNI armonizzate e nazionali, le direttive Europee e le disposizioni italiane sulla sicurezza del lavoro.

*Prima dell'utilizzo delle staffe di sollevamento leggere attentamente il manuale di uso e manutenzione.*

*Un uso improprio o contrario, a quanto prescritto nel manuale, rende nulla la validità della presente dichiarazione **CE** di conformità e solleva l'OMCR da ogni responsabilità in merito.*

**OMCR S.r.l.**

Il legale rappresentante  
Domenico Zentilin







Betriebs- und Instandhaltungsanleitung  
mit **CE**-Konformitätserklärung

# TRAGWANGEN MIT BOLZEN



Artikelnummern: **B01.35 - B02.45**

## INHALTSVERZEICHNIS

1. RISIKOBEURTEILUNG .....	.27
2. ZEICHENERKLÄRUNG .....	.27
3. ANWENDUNG .....	.28
4. TRANSPORT UND LAGERUNG .....	.34
5. INSTANDHALTUNG .....	.35
EC-Konformitätserklärung .....	.36

## 1. RISIKOBEURTEILUNG

Der Inhalt der folgenden Seiten bezieht sich auf die klassische Anwendung der Tragwange und kann unspezifische Anwendungen nicht vorhersehen. Aus diesem Grund muss jeder Anwender eine eigene Risikobeurteilung vornehmen und diese Betriebsanleitung als allgemeine Richtlinie berücksichtigen, unter Berücksichtigung der Notwendigkeit der Synthese bei der Abhandlung der Argumente. Es bleibt die Aufgabe des Anwenders, unter seiner Verantwortung, die Anwendungsverfahren zur Durchführung der Arbeitsgänge für die Mitarbeiter zu definieren, darüber zu informieren und deren Einhaltung zu überprüfen.









Die Tragwangen dienen als Haken für Seile oder Ketten und gestatten eine sichere Durchführung folgender Arbeitsgänge: HEBEN, BEWEGEN und WENDEN. Das Material, die Herstellung und die Kontrolle aller **OMCR** Tragwangen entspricht den Anforderungen der Richtlinie **2006/42/EG**. Alle Tragelemente von **OMCR** sind mit einem statischen Prüfungskoeffizienten von mindestens 1,5 geprüft, an allen Materialien wurden Analysen gemäß **UNI EN 10204** durchgeführt, stichprobenmäßig werden konventionelle Zugprüfungen gemäß **UNI EN 10002** durchgeführt.

### ANMERKUNG

***Vor dem Einsatz der Tragwangen die Betriebs- und Instandhaltungsanleitung aufmerksam lesen. Ein unsachgemäße oder gegenteilige Anwendung ggü. den in dieser Betriebsanleitung beschriebenen Punkten enthebt OMCR von jeglicher Verantwortung hinsichtlich der Sicherheit der hier zitierten Elemente***

## 2. ZEICHENERKLÄRUNG

Die folgenden Sicherheitshinweise und Symbole der vorliegenden Betriebs- und Instandhaltungsanleitung sind gemäß den Normen ISO 3864-2 und ANSI Z535.6 klassifiziert worden:

 <b>WARNUNG</b>	Zeigt eine potentiell gefährliche Situation an, die, wenn sie nicht vermieden wird, zu schweren Unfälle oder zum Tod führen kann.
 <b>VORSICHT</b>	Zeigt eine potentiell gefährliche Situation an, die, wenn sie nicht vermieden wird, zu leichten bis mittelschweren Verletzungen führen kann.
<b>NOTE</b>	Weist auf Anregungen oder andere Informationen von besonderer Wichtigkeit hin.
	Allgemeine Gefahr.
	Quetschgefahr mit daraus folgendem Fallen oder Umkippen der Ladung.
	Schergefahr mit daraus folgendem Fallen oder Umkippen der Ladung.
	Schergefahr mit daraus folgendem Fallen oder Umkippen der Ladung.
	Verbotene Tätigkeit bzw. Anwendungsart.
	Tätigkeiten, die auszuführen sind, um Risiken zu vermeiden.
	Es ist verboten sich aufzuhalten oder durchzugehen.

### 3. ANWENDUNG

#### 3.1

##### ⚠️ WARNUNG



Jedes Heben / Bewegen muss von qualifiziertem und entsprechend ausgebildetem Personal ausgeführt werden. Den für das Heben / Bewegen / Wenden zuständigen Personen müssen individuelle Schutzeinrichtungen zur Verfügung gestellt werden, die sie verwenden müssen.

#### 3.2

##### ⚠️ WARNUNG



Vor jedem Heben / Bewegen müssen die hierfür Zuständigen die am besten geeignete Anschlagart wählen, um eine sicheres Aufhängen mit einem korrekten Gleichgewicht der Ladung zu gewährleisten. Die effektive Tragkraft der Seile / Ketten und des Hebezubehörs kann durch eine nicht korrekte Anschlagart verändert werden. In der folgenden Tabelle kann man die Reduzierung der Nominaltragkraft in Funktion des Neigungswinkels beurteilen, um den Sicherheitsfaktor konstant zu halten.

##### ANMERKUNG

Zur Definition des symmetrischen oder asymmetrischen Anschlags siehe Norm EN 818-06: Im Falle eines asymmetrischen Anschlags wird angenommen, dass das zu hebende Gewicht nur von zwei Strängen des Seils bzw. der Kette getragen wird.

#### 3.2.1 - HEBEN

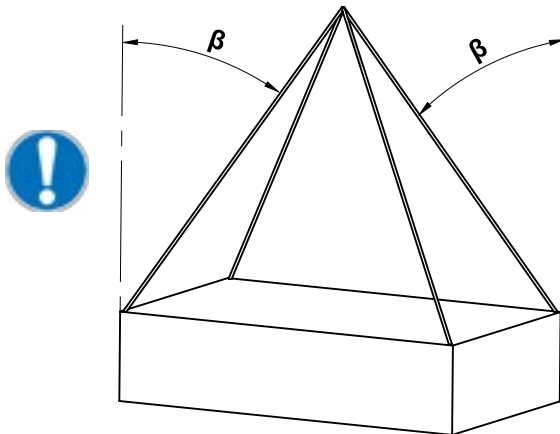

##### Beispiel: SYMMETRISCHER ANSCHLAG (empfohlen)

Neigungswinkel	Reduktionsfaktor der Nominaltragkraft
$0^\circ \leq \beta \leq 40^\circ$	1
$40^\circ < \beta \leq 50^\circ$	0.84
$50^\circ < \beta \leq 60^\circ$	0.65

**G** = Schwerpunkt Werkzeug

**β** = Neigungswinkel

**Anmerkung:** Das Heben mit  $\beta > 60^\circ$  ist nicht vorgesehen

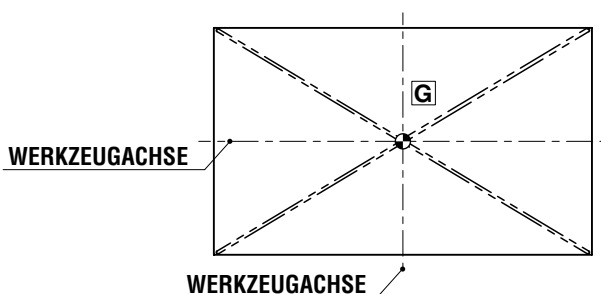

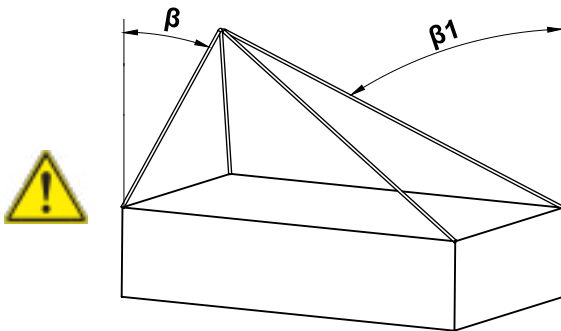

**Beispiel: ASYMMETRISCHER ANSCHLAG**

**Reduktionsfaktor der Nominaltragkraft**

0.5

**G** = Schwerpunkt Werkzeug

$\beta$  = min. Neigungswinkel

$\beta_1$  = max. Neigungswinkel

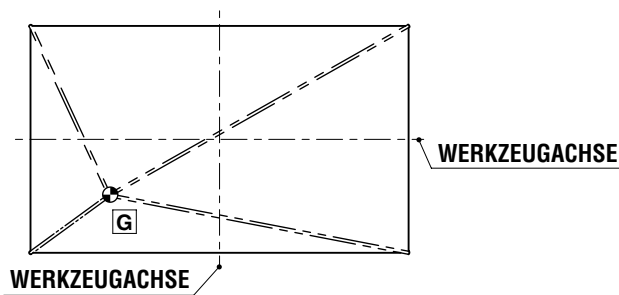

**! WARNUNG**

Das Nichtbeachten der in dieser Anleitung enthaltenen Vorschriften kann ein Herabfallen der Ladung hervorrufen.

**3.2.2 - WENDEN**

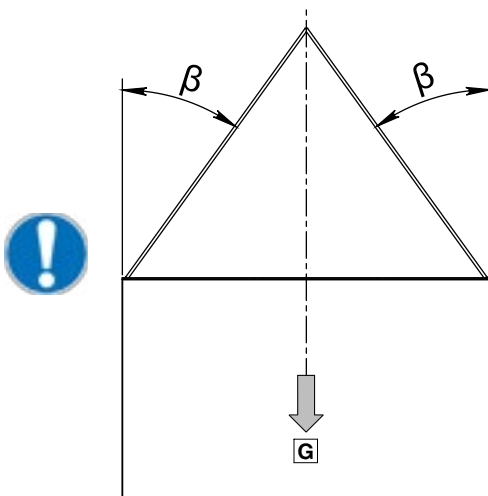

**Beispiel: SYMMETRISCHER ANSCHLAG  
(empfohlen)**

Neigungswinkel	Reduktionsfaktor der Nominaltragkraft
$0^\circ \leq \beta \leq 40^\circ$	0.6
$40^\circ < \beta \leq 50^\circ$	0.5
$50^\circ < \beta \leq 60^\circ$	0.4

**G** = Schwerpunkt Werkzeug

$\beta$  = Neigungswinkel

**Anmerkung:** das Heben mit  $\beta > 60^\circ$  ist nicht vorgesehen.

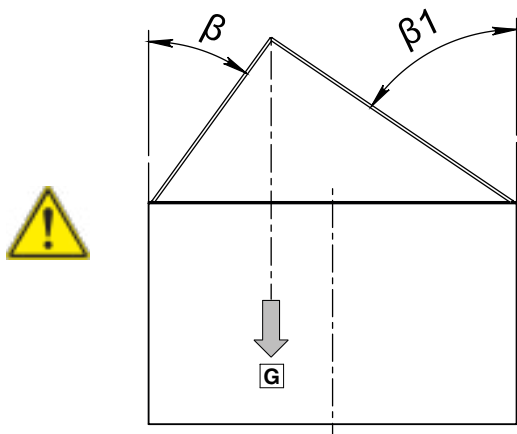

**Beispiel: ASYMMETRISCHER ANSCHLAG**  
( $\beta_1 > \beta$ )

Neigungswinkel	Reduktionsfaktor der Nominaltragkraft
$\beta < 15^\circ$	0.5
$\beta > 40^\circ$	
$\beta_1 - \beta > 15^\circ$	

**G** = Schwerpunkt Werkzeug

**$\beta$**  = min. Neigungswinkel

**$\beta_1$**  = max. Neigungswinkel

**⚠️ WARNUNG**

Das Nichtbeachten der in dieser Anleitung enthaltenen Vorschriften kann ein Herabfallen der Ladung hervorrufen.

**3.2.3**

**⚠️ WARNUNG**



Das Wenden des Werkzeugs kann nur parallel zu den Achsen des Tragbolzens erfolgen.

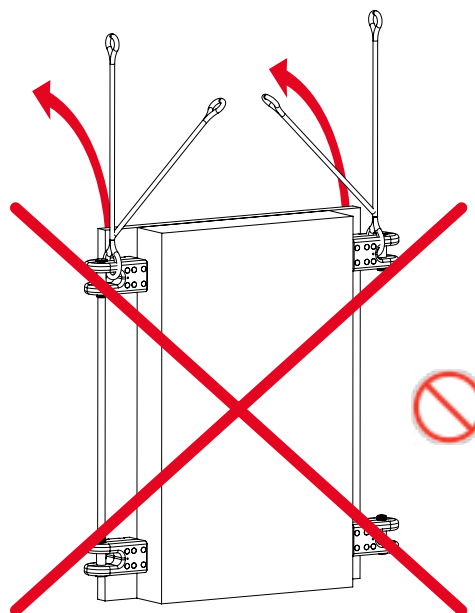
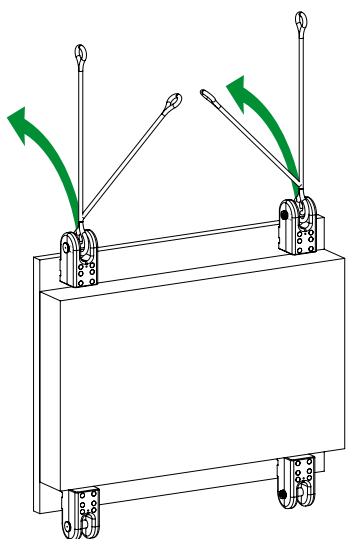

### 3.3

#### ⚠️ WARNUNG



Bei der Montage prüfen, ob die Schrauben korrekt angezogen sind. In der Tabelle unten sind Schraubentyp und Anziehdrehmoment zur Befestigung der jeweiligen Tragwange aufgeführt. **Es empfiehlt sich Kleber LOCTITE 243 oder Sicherheitsbeilagscheiben zum Sichern der Schrauben zu verwenden. Es muss unbedingt eine Einschraubtiefe von mindestens  $1 \times \varnothing$  der Schraube gewährleistet sein.**

ART.-NUM. STAFFA	NR. VITI	VITE DIN 912 CL. 8.8	COPPIA DI SERRAGGIO [Nm]
B01.35.42500	6	M36	2481

#### ⚠️ WARNUNG

Das Nichtbeachten der in dieser Anleitung enthaltenen Vorschriften kann ein Herabfallen der Ladung hervorrufen.

### 3.4

#### ⚠️ WARNUNG



Die Tragwangen **B01.25. müssen auf Stahlplatten montiert werden (Qualität min. St52).**  
Die Tragwangen **B01.25. müssen mit Passfeder montiert werden (siehe Fig.1).**

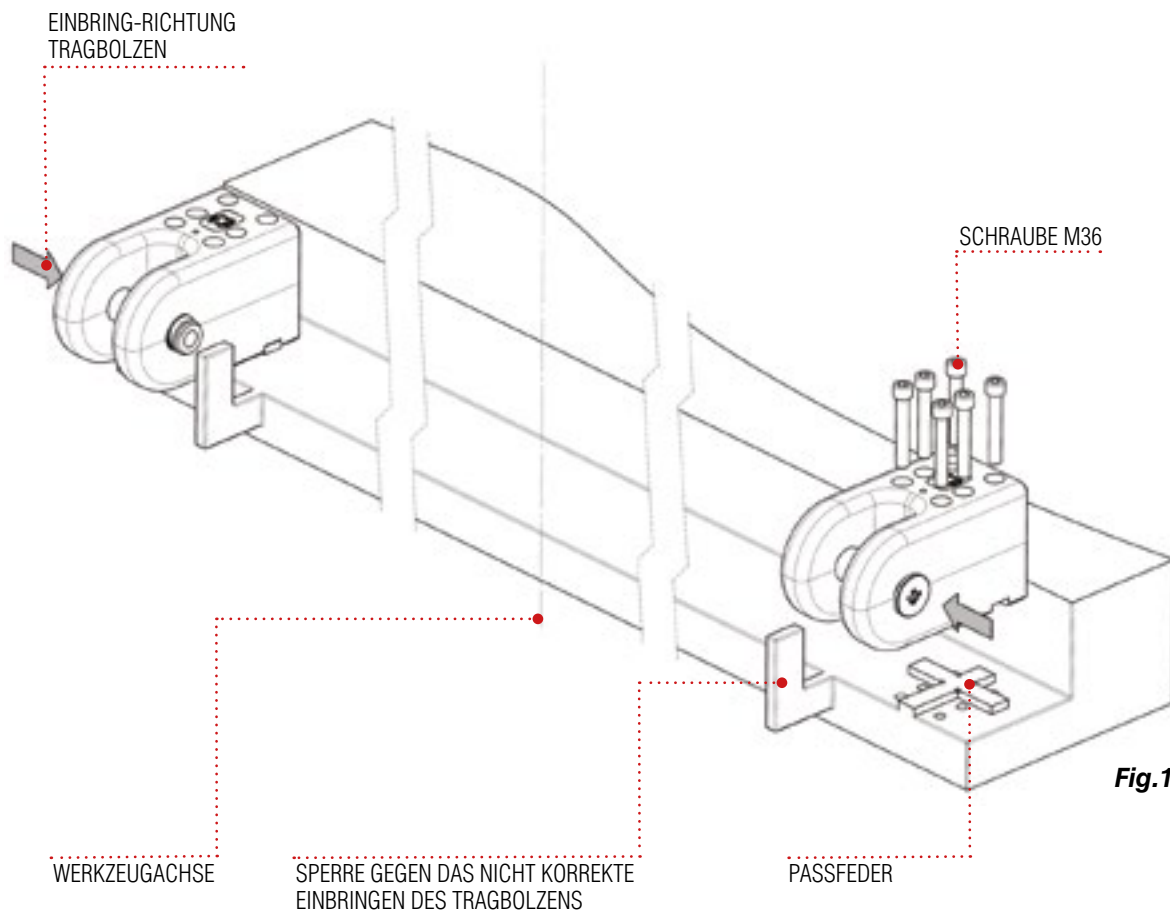

Fig.1

3.5

**⚠️ WARNUNG**



Vor jedem Heben / Bewegen / Wenden des Werkzeugs prüfen, dass der Tragbolzen korrekt montiert ist. Der Tragbolzen muss **UNBEDINGT** mit dem **Sicherheitsring** in Richtung der Werkzeugachse gerichtet montiert sein: Nach dem Einbringen muss sichergestellt werden, dass der Sicherheitsring ggü. dem Loch außermittig sitzt und der Tragbolzen nicht herausrutschen kann. Prüfen, ob sich der **Sicherheitsring bewegt und die Außermittigkeit "E" gegenüber dem Tragbolzen prüfen** (siehe Fig.2).

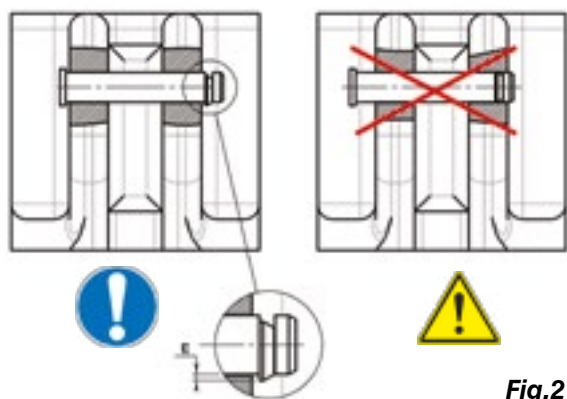

CODICE STAFFE	CODICE PERNI
B01.35.42500	B02.45.100

Fig.2

3.6

**⚠️ WARNUNG**



Vor jedem Heben / Bewegen / Wenden prüfen, dass die Tragkraft der Tragwangen gemäß dem Werkzeuggewicht ist (**ausgewiesen auf entsprechendem Schild**). Die maximale Tragkraft, das Produktionslos, das Herstellerlogo, das CE-Zeichen, die Art.-Nr. und das Material sind unauslöschlich auf Tragbolzen und Tragwange markiert. **ANMERKUNG:** es besteht keine Verbindung zwischen den Produktionslosen der Tragwangen und der Tragbolzen.



Fig.3



Beim Heben und Bewegen muss die Tragkraft der Tragwangen mindestens gleich der Hälfte des Gesamtgewichts des Werkzeugs sein (oberen Werkzeughälfte + untere Werkzeughälfte).

Beispiel: Gewicht Werkzeug 85.000 kg - Portata minima della staffa :  $85.000 / 2 = 42.500$  kg

Beim Wenden einer Werkzeughälfte muss die Tragkraft der Tragwange mindestens gleich der Hälfte des Gewichts der Werkzeughälfte sein.

Beispiel: Gewicht Werkzeughälfte 42.500 kg - Mindesttragkraft der Tragwange:  $42.500 / 2 = 21.250$  kg

### 3.7

#### **⚠️ WARNUNG**



Vor jedem Heben / Bewegen / Wenden des Werkzeugs prüfen, dass die gewählte Anschlagart (Seil/Kette, Haken, etc.) keinen Fehler oder Deformationen aufweist, die sie unsicher machen. In diesem Fall **sofort die defekten Teile entfernen**.

### 3.8

#### **⚠️ WARNUNG**



Das Heben / Bewegen / Wenden nicht mit Anschlägen, die Winkel größer 90° ggü. der Horizontalen formen, durchführen, da ansonsten der Tragbolzen herausrutschen kann und das Risiko besteht, dass die Ladung fällt (siehe **Fig.4**).

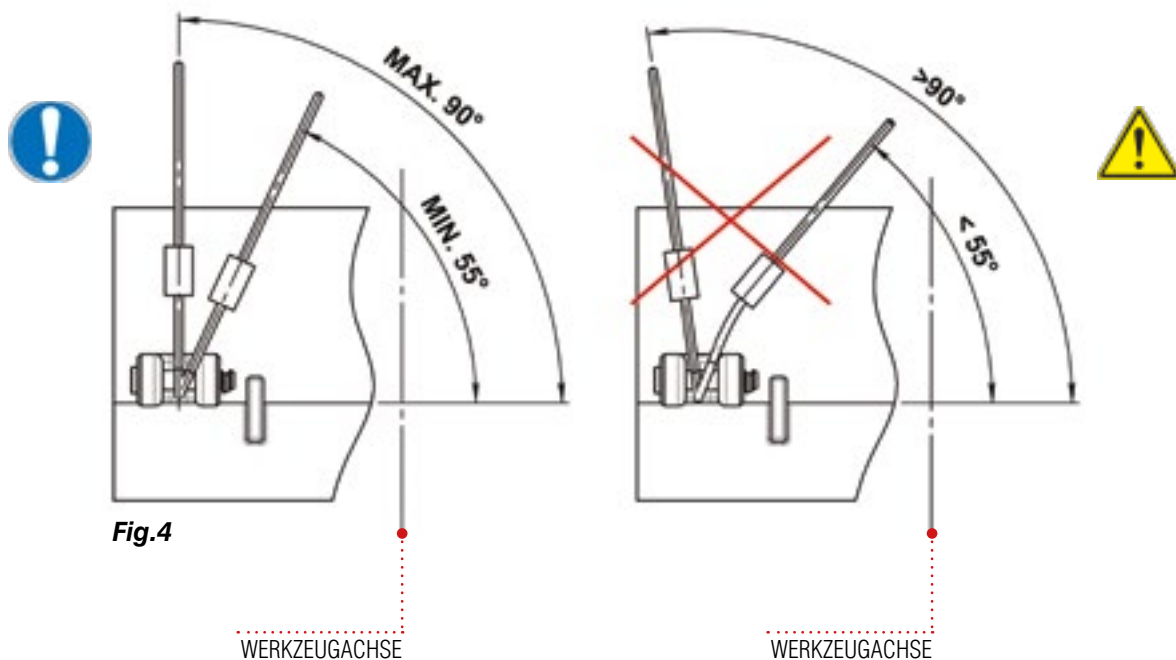

**Fig.4**

**Fig.4**

### 3.9

#### **⚠️ WARNUNG**



Sich vor jedem Heben / Bewegen / Wenden des Werkzeugs versichern, dass:

- die Seile / Ketten korrekt gesichert sind;
- die Seile / Ketten nicht in Kontakt mit schneidenden Kanten sind und;
- die Seile / Ketten nicht in Kanten des Werkzeugs verhakt sind.

### 3.10

#### **⚠️ WARNUNG**



Während dem Heben / Bewegen / Wenden (siehe **Fig.5**) darf man sich nicht in der Nähe der Ladung aufhalten bzw.



**Fig.5**

## 4. TRANSPORT UND LAGERUNG

### 4.1

#### **⚠️ WARNUNG**



Hier sind die Gewichte der Tragwangen OMCR Art.-NR. B01.35 angegeben. Die Tragwangen müssen gemäß den geltenden Normen zum manuellen Transport von Ladungen bewegt werden (siehe **Fig.6**)

Tragwange Art.-Nr.	Gewicht (kg) inkl. Tragbolzen
B01.24.08000	24
B01.24.12500	50,5



**Fig.6**

**4.2** Die Tragwangen müssen an einem vor Feuchtigkeit geschützten Ort gelagert werden, wenn sie nicht in Gebrauch sind, und durch das Aufbringen von Schutzöl vor Oxidation geschützt werden.

## 5. INSTANDHALTUNG

**5.1** Alle 6 Monate Sichtkontrollen durchführen, um das Vorhandensein von sichtbaren Anomalien oder das Auftreten einer Oxidation zu prüfen: In diesem Fall den Originalzustand wieder herstellen oder die Tragwangen oder Tragbolzen austauschen.

**5.2** Mindestens alle 12 Monate eine Prüfung der Zylindrizität durchführen, um eventuelle permanente Deformationen (siehe **Fig.6**) auszuschließen: Bei Abweichungen, die größer als 0,3 mm sind, die jeweiligen Tragbolzen austauschen.

**5.3** Alle 6 Monate kontrollieren, ob die Befestigungsschrauben korrekt, gemäß der in dieser Betriebs- und Instandhaltungsanleitung enthaltenen Tabelle, angezogen sind.

**5.4** Sollten die tragenden Seile / Ketten plötzlich reißen, mit daraus folgender Überbelastung der Tragbolzen und der Tragwangen, müssen diese auf Ihre Zylindrizität (siehe **Fig.6**) geprüft werden, um evtl. Deformationen auszuschließen. Bei Abweichungen, die größer als 0,3 mm sind, die jeweiligen Tragbolzen austauschen, die Befestigungsschrauben austauschen und prüfen, ob sie korrekt gemäß der Tabelle in dieser Betriebs- und Instandhaltungsanleitung angezogen sind.

**5.5** Nach unvorhergesehenen Stößen in den Anschlagbereichen während des Hebens/Bewegens/Wendens müssen die Tragbolzen auf Ihre Zylindrizität geprüft werden, um evtl. Deformationen auszuschließen. Bei Abweichungen, die größer als 0,3 mm (siehe **Fig.6**) sind, die jeweiligen Tragbolzen austauschen. Die Tragwangen einer Sichtkontrolle unterziehen, um eventuelle Deformationen auszuschließen bzw. sie bei Bedarf austauschen, die Befestigungsschrauben austauschen und prüfen ob sie korrekt, gemäß der Tabelle in dieser Betriebs- und Instandhaltungsanleitung, angezogen sind.

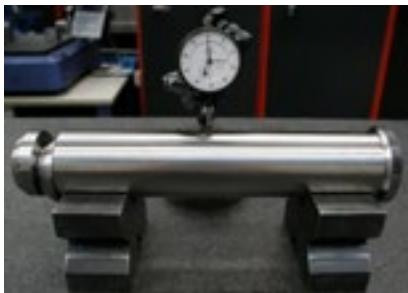

**Fig.6**

## EC-Konformitätserklärung

(Maschinenrichtlinie 2006/42/CE)

Die Firma OMCR S.r.l. mit Sitz in Via Quarantelli, 8 – 10077 S. Maurizio C.se – (Turin -Italien) erklärt in Person seines gesetzlichen Vertreters, dass die

### **TRAGWANGEN MIT BOLZEN MIT FALLRINGSICHERUNG**

#### **mit der Artikelnummer: B01.35 – B02.45**

auf jedem einzelnen Teil eine Produktionslos-Nummer geprägt haben, anhand der man jederzeit auf die in der technischen Abteilung archivierten Unterlagen zurückgreifen kann und somit jede Eigenschaft und jedes Produktions- und Prüfelement identifizieren kann.

Alle Qualitäts- und Sicherheitsverfahren wurden zusammengestellt von Herrn Bertorello, verantwortlich für die technischen Unterlagen, tätig bei OMCR Srl., Via Quarantelli 8, I-10077 San Maurizio C.se (TO). Sie wurden korrekt durchgeführt und dadurch wurde die

Berechtigung erlangt, das Schriftbild **CE** aufzuprägen, um zu garantieren, dass diese Teile:

- den in der Maschinenrichtlinie 2006/42/CE vom 09.06.2006 festgelegten Bedingungen entsprechen und
- Kontrollen und Prüfungen unterzogen worden sind, die belegen dass diese Produkte auch den harmonisierten und nationalen UNI Normen, den europäischen Richtlinien und den italienischen Vorschriften hinsichtlich der Arbeitssicherheit entsprechen.

*Vor dem Einsatz der Tragwangen die Betriebs- und Instandhaltungsanleitung aufmerksam lesen.*

*Ein unsachgemäßer oder gegenteiliger Einsatz ggü. dem in der Anweisung beschriebenen Inhalt setzt die Gültigkeit dieser EG-Konformitätserklärung außer Kraft und enthebt die Firma OMCR von jeglicher Verantwortung diesbezüglich.*

*Diese Betriebs- und Instandhaltungsanleitung mit EG-Konformitätserklärung wurde aus dem Italienischen übersetzt, im Falle von Beanstandungen hat die italienische Version rechtliche Gültigkeit.*



**OMCR S.r.l.**

*Il legale rappresentante  
Domenico Zentilin*





Manual de uso y mantenimiento  
completo de declaracion **CE** de conformidad

# DISPOSITIVO DE ELEVACION LATERAL CON BULON



Codigos de articulo: **B01.35 - B02.45**

## ÍNDICE

1. VALORACION DE RIESGOS . . . . .	.39
2. SIMBOLOGIA Y CLASIFICACION DE LAS ADVERTENCIAS . . . . .	.39
3. UTILIZATION . . . . .	.40
4. MANUTENCION Y ALMACENAMIENTO . . . . .	.46
5. MANTENIMIENTO . . . . .	.47
DECLARATION CE DE CONFORMIDAD. . . . .	.48

## 1. VALORACION DE RIESGOS

El contenido de las siguientes páginas hace referencia al uso habitual de los dispositivos de elevacion lateral con bulón, y no puede prever usos no específicos. Por esta razón cada usuario debe tener en cuenta su propia valoración de riesgos, y utilizar este manual como referencia general, considerando la necesidad de síntesis de sus argumentos. Es competencia y responsabilidad del usuario definir a los operarios los procedimientos de uso, verificar su cumplimiento y facilitarles información.



Los dispositivos de elevación lateral con bulón funcionan con un gancho para eslinga o cadena, y permiten efectuar con seguridad operaciones de: TRANSPORTE, DESPLAZAMIENTO, VOLTEO; el material, fabricación y control de calidad de todos los bulones de transporte OMCR son conformes a la directiva **2006/42/CE**; todos los elementos de transporte OMCR son verificados con un coeficiente de prueba estática mínimo de 1.5. Son efectuados análisis sobre todos los materiales según **UNI EN 10204**, sobre las muestras se hacen pruebas de tracción convencional conforme a **UNI EM 10002**.

### **ADVERTENCIA**

***Un uso impropio o contrario a lo indicado en este manual exime a OMCR de cualquier responsabilidad sobre la seguridad de de los elementos citados.***

## 2. SIMBOLOGIA Y CLASIFICACION DE LAS ADVERTENCIAS

Según las normativas ISO 3864-2, ANSI Z535.6, ANSI Z535.4, en este manual se han clasificado los siguientes mensajes de seguridad y sus símbolos:

 <b>ADVERTENCIA</b>	Indica una situación potencialmente peligrosa que de no evitarse puede provocar daños importantes o la muerte.
 <b>ATENCIÓN</b>	Indica una situación potencialmente peligrosa que de no evitarse puede provocar lesiones leves o moderadas.
<b>NOTA</b>	Indica sugerencias u otras informaciones de especial importancia
	Indica un peligro genérico.
	Indica un riesgo de aplastamiento como consecuencia de caída o vuelco de la carga.
	Indica riesgo de cizallamiento como consecuencia de la caída o vuelco de la carga.
	Indica un riesgo músculo-esquelético como consecuencia del manejo manual de la carga.
	Indica operaciones o modos de uso prohibidos.
	Indica acciones a efectuar para evitar riesgos.
	Indica la prohibición de detenerse o transitar.

### 3. UTILIZATION

#### 3.1

##### ⚠ ADVERTENCIA



Cada operación de transporte, desplazamiento o volteo tiene que ser efectuada por personal cualificado y debidamente formado; los encargados del transporte, desplazamiento, volteo deben usar los medios de protección individual adecuados.

#### 3.2

##### ⚠ ADVERTENCIA



Antes de cada operación de transporte, desplazamiento o volteo los operarios deben elegir el anclaje idóneo para garantizar una suspensión segura con un correcto equilibrio de la carga. La carga efectiva de las eslingas / cadenas y de los accesorios de transporte puede ser alterada por el uso de un anclaje incorrecto. La siguiente tabla permite valorar la reducción de la carga nominal en función del ángulo del anclaje de seguridad con el fin de mantener constante el factor de seguridad.

##### NOTE

Para la definición de arneses simétricos o asimétricos ver norma EN818-06: en caso de arneses asimétricos, se considera que el peso a levantar sea soportado por sólo dos brazos de cuerda o cadena.

#### 3.2.1 - ELEVACION

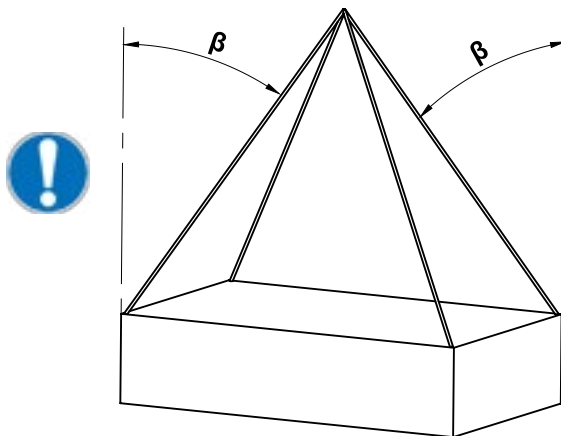

##### EJEMPLO DE ARNESES SIMETRICOS (CONDICION ACONSEJADA)

ANGULO	FACTOR DE REDUCCION DE CARGA DE LA OREJETA
$0^\circ \leq \beta \leq 40^\circ$	1
$40^\circ < \beta \leq 50^\circ$	0.84
$50^\circ < \beta \leq 60^\circ$	0.65

**G** = Centro de gravedad del troquel

**β** = Ángulo de las cuerdas/cadenas desde la vertical

**NOTA:** la elevación con  $\beta > 60^\circ$  no está prevista

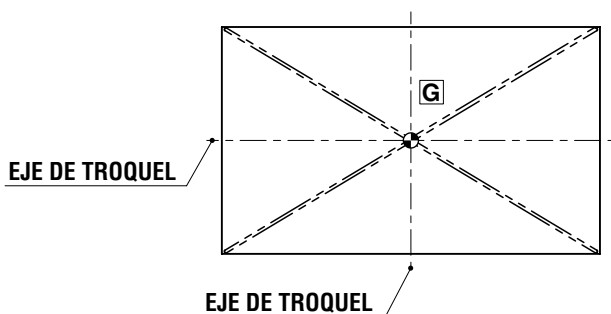



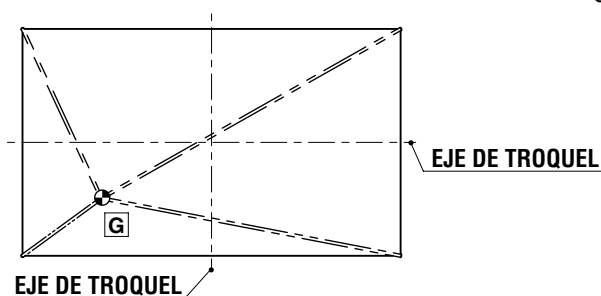
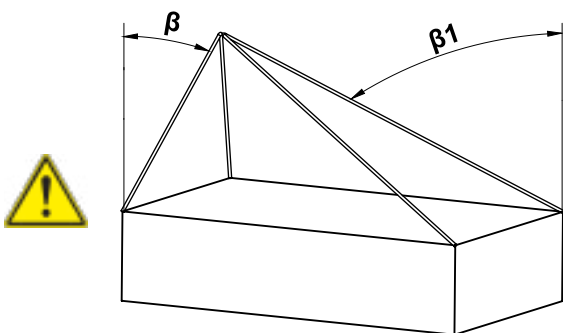

**EJEMPLO DE ARNESES ASIMETRICOS**

**FACTOR DE REDUCCION DE CARGA DE LA OREJETA**

0.5

**G** = Centro de gravedad del troquel

**β** = Ángulo de la cuerda/cadena mínimo desde la vertical

**β1** = Ángulo de la cuerda/cadena máximo desde la vertical

**⚠ ADVERTENCIA**

El no cumplimiento de las prescripciones contenidas en el presente manual puede provocar riesgo de caída accidental de la carga.

**3.2.2 - VOLTEO**

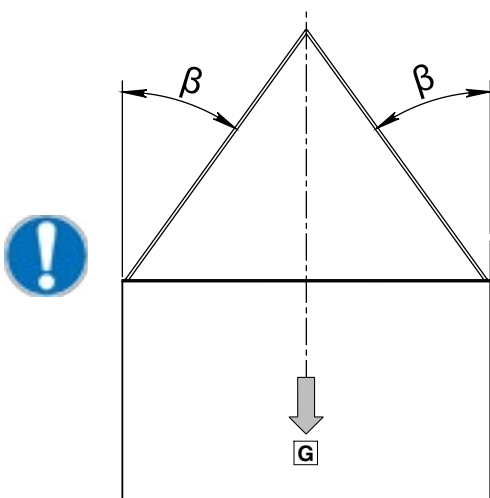

**EJEMPLO DE ARNESES SIMETRICOS  
(CONDICION ACONSEJADA)**

ANGULO	FACTOR DE REDUCCION DE CARGA DE LA OREJETA
$0^\circ \leq \beta \leq 40^\circ$	1
$40^\circ < \beta \leq 50^\circ$	0.84
$50^\circ < \beta \leq 60^\circ$	0.65

**G** = Centro de gravedad del troquel

**β** = Ángulo de las cuerdas/cadenas desde la vertical

**NOTA:** la elevación con  $\beta > 60^\circ$  no está prevista

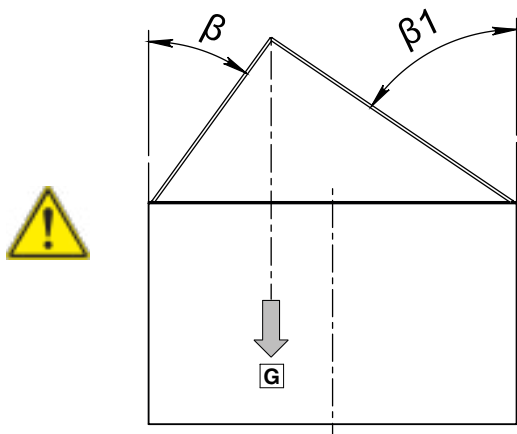

**EJEMPLO DE ARNESES ASIMÉTRICAS  
( $\beta_1 > \beta$ )**

ANGULO	FACTOR DE REDUCCION DE CARGA DE LA OREJETA
$\beta < 15^\circ$	0.5
$\beta > 40^\circ$	
$\beta_1 - \beta > 15^\circ$	

**G** = Centro de gravedad del troquel

**$\beta$**  = Ángulo de la cuerda/cadena mínimo desde la vertical

**$\beta_1$**  = Ángulo de la cuerda/cadena máximo desde la vertical

**⚠ ADVERTENCIA**

*El no cumplimiento de las prescripciones contenidas en el presente manual puede provocar riesgo de caída accidental de la carga.*

**3.2.3**

**⚠ ADVERTENCIA**



*El volteo del troquel debe efectuarse sólo en paralelo al eje del bulón de transporte.*

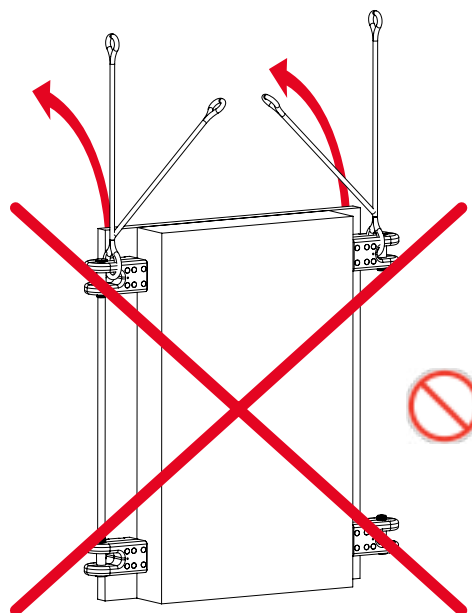
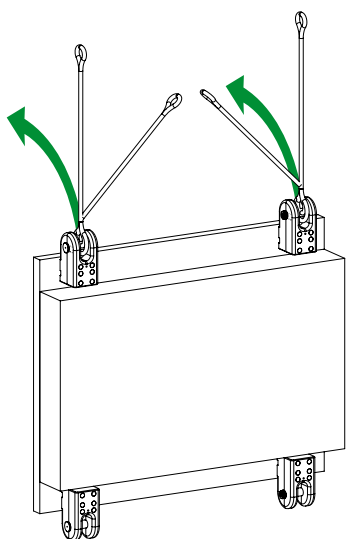

### 3.3

#### **⚠ ADVERTENCIA**



Antes de empezar la operación verificar el correcto apriete de los tornillos; en la siguiente tabla se indican los tornillos y pares de apriete para la fijación de las orejetas; **se aconseja el uso de pegamento de fijación LOCTITE 243 o arandelas grower. Garantizar taxativamente alojamiento de 1 x Ø tornillo. EJ: para tornillos M36, alojamiento mínimo de 36mm.**

ART.-NUM. STAFFA	NR. VITI	VITE DIN 912 CL. 8.8	COPPIA DI SERRAGGIO [Nm]
B01.35.42500	6	M36	2481

#### **⚠ ADVERTENCIA**

**El no cumplimiento de las prescripciones contenidas en el presente manual puede provocar riesgo de caída accidental de la carga.**

### 3.4

#### **⚠ ADVERTENCIA**



**Las orejetas B01.24 deben ser montadas sobre placas de acero (calidad mínima Fe510, S355) con chavetas; se aconseja el uso de topes para impedir la introducción incorrecta de los bulones (ver Fig.1).**

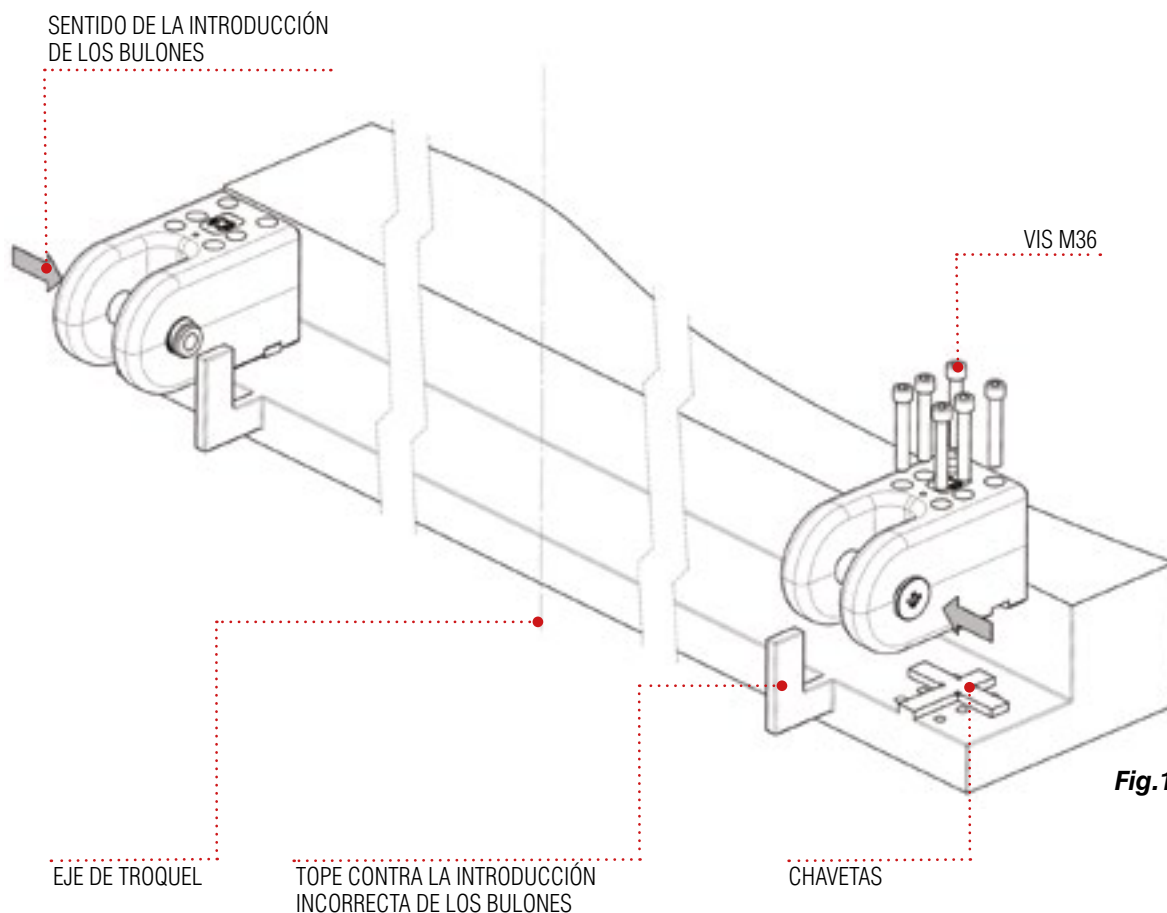

**Fig.1**

### 3.5

#### ⚠ ADVERTENCIA



Antes de cada transporte, desplazamiento o volteo del troquel asegurarse del correcto posicionamiento del bulón de transporte que debe **IMPERATIVAMENTE** ser montado con el **anillo de seguridad** vuelto hacia el eje del troquel: después de haberlo introducido verificar que el **anillo de seguridad** sea desplazado de su eje respecto al agujero e impida la extracción del bulón; verificar el movimiento del **anillo de seguridad** comprobando la excentricidad "E" respecto del bulón (ver **Fig.3**).

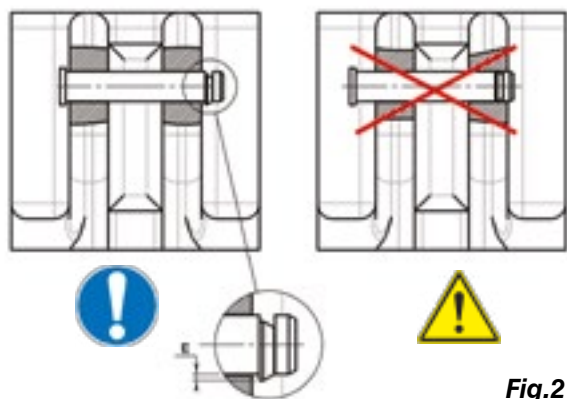

Fig.2

CODIGO OREJETA	CODIGO BULONES
B01.35.42500	B02.45.100

### 3.6

#### ⚠ ADVERTENCIA



Antes de cualquier elevación, desplazamiento o volteo verificar que la capacidad de carga de las orejetas se apropiada para el peso del troquel; la carga máxima, la orden de fabricación, el logo del fabricante, el sello de conformidad CE, el código de artículo y el material son marcados de modo indeleble en el bulón y la orejeta. (ver **Fig.3**). **NOTA:** no tiene por qué haber correspondencia entre la orden de fabricación de la orejeta y del perno.



Fig.3

La carga del dispositivo de elevación lateral no debe ser inferior a **1/2** del peso total del troquel en el caso de transporte y desplazamiento (semistampo superior + semistampo inferior).

Es: Peso stampo 85.000 kg - portata minima della staffa:  $85.000 / 2 = 42.500$  kg

La carga del dispositivo de elevación lateral no debe ser en absoluto inferior a **1/2** del peso del semitroquel en el caso de volteo.

Es: Peso semistampo 42.500 kg - portata minima della staffa:  $42.500 / 2 = 21.250$  kg

### 3.7

#### ⚠ ADVERTENCIA



Antes de cada transporte, desplazamiento o volteo del troquel verificar que el anclaje elegido (eslinga / cadena, gancho, etc.) no presente defectos o fallos que puedan volverlo inseguro; en tal caso **eliminar inmediatamente las partes defectuosas**.

### 3.8

#### ⚠ ADVERTENCIA



No efectuar transporte, desplazamiento o volteo con anclajes con ángulos superiores a  $90^\circ$  respecto a la horizontal, en caso contrario se puede producir la extracción del bulón con riesgo de caída de la carga (ver Fig.4).

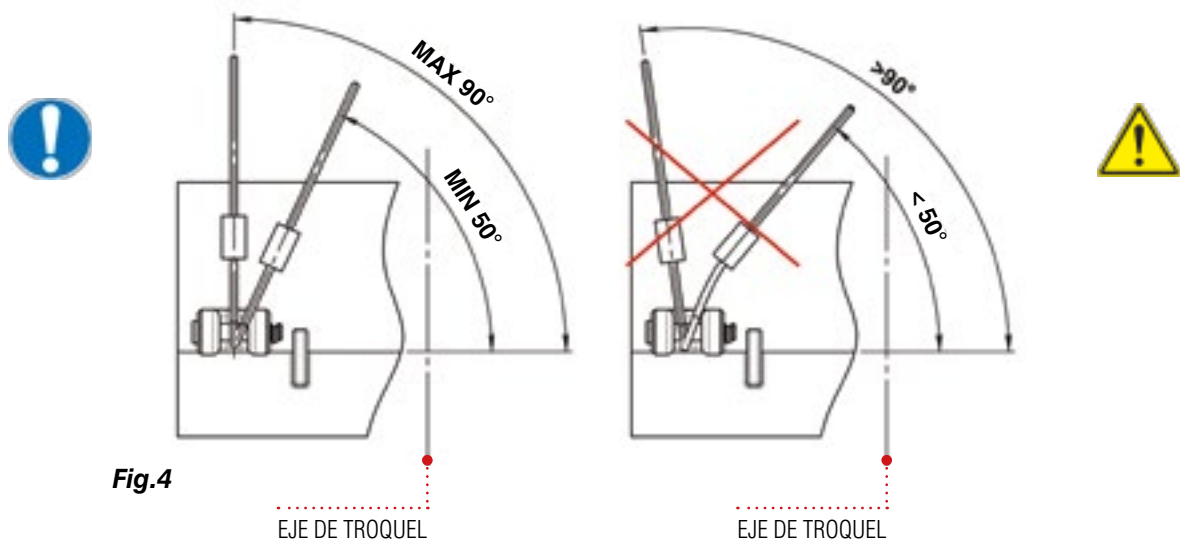

### 3.9

#### ⚠ ADVERTENCIA



Antes de cada elevación o desplazamiento del troquel verificar que:

- las cuerdas/cadenas estén aseguradas correctamente;
- las cuerdas/cadenas no estén en contacto con bordes afilados;
- las cuerdas / cadenas no están comprometidos en las esquinas del molde.

### 3.10

#### **⚠ ADVERTENCIA**



No permanecer cerca de la carga durante las operaciones de transporte, desplazamiento o volteo (ver Fig.6). En caso de enganche accidental de la carga puede haber riesgo de lesión



Fig.5

## 4. MANUTENCION Y ALMACENAMIENTO

### 4.1

#### **⚠ ADVERTENCIA**



A continuación se indican los pesos de las orejetas OMCR cód. B01.35. **Para el traslado de las orejetas B01.35 utilizar el agujero de elevación de M20** (ver Fig.6)

OMCR CODE	PESO (kg) <i>completa con bulón</i>
B01.24.08000	24
B01.24.12500	50,5

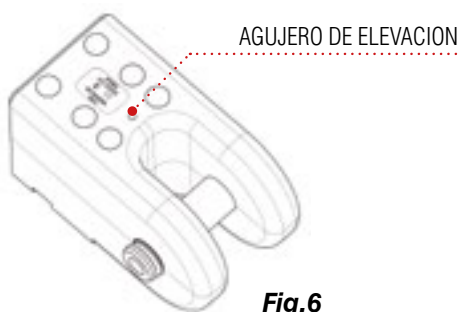

Fig.6

**4.2** Los dispositivos de elevación lateral con bulón deben ser almacenados en un lugar libre de humedad en caso de no utilización, y protegidos de la oxidación aplicando un aceite protector.

### 4.2.1

#### **⚠ ADVERTENCIA**



**En el momento del montaje limpiar la superficie de contacto entre la orejeta de transporte y la placa portatroquel.**

La presencia de aceite o impurezas entre la superficie de apoyo de la orejeta de transporte y la superficie de la placa portatroquel puede comprometer el correcto funcionamiento de la orejeta.

## 5. MANTENIMIENTO

**5.1** Efectuar cada 6 meses controles visuales para verificar la presencia de anomalías visibles o apariciones de oxidación: en ese caso, reponer o sustituir los dispositivos de elevación lateral o los bulones afectados.

**5.2** Efectuar al menos cada 12 meses un control de cilindridad para verificar eventuales deformaciones permanentes. (**Fig.6**); en el caso de errores superiores a 0.25mm sustituir los bulones afectados.

**5.3** Efectuar cada 6 meses controles sobre el correcto apriete de los tornillos de sujeción según la tabla indicada en el manual.

**5.4** En el caso de que se verifique que las eslingas/cadenas han cedido, con la consiguiente sobrecarga de los bulones de transporte, someterlos a controles de cilindridad (ver **Fig.6**) para verificar eventuales deformaciones; en el caso de errores superiores a 0.25 mm sustituir los bulones afectados; sustituir los tornillos de sujeción y verificar el apriete correcto según la tabla indicada en el manual.

**5.5** En el caso de golpes accidentales en la zona de anclaje durante las operaciones de transporte, desplazamiento y volteo, someter a los bulones a controles de cilindridad para verificar eventuales deformaciones; en caso de errores superiores a 0.25 mm sustituir los bulones afectados; someter los dispositivos de elevación lateral a control visual para verificar eventuales deformaciones, y en tal caso sustituirlos; sustituir los tornillos de sujeción y verificar el apriete correcto según la tabla indicada en el manual.

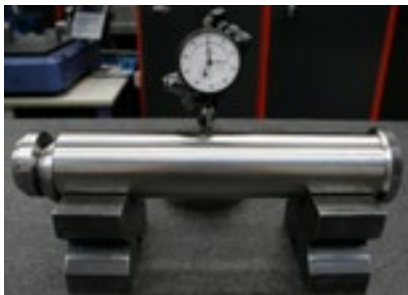

**Fig.6**

# DECLARATION **CE** DE CONFORMIDAD

(Directiva Maquinaria 2006/42/CE )

OMCR S.r.l. con sede in Via Quarantelli, 8 – 10077 S.Maurizio C.se – (Turín-Italia) a través de su representante legal, declara que los:

## **DISPOSITIVOS DE ELEVACION LATERAL CON BULON (VW-AUDI)**

### **Código de producto: B01.35 – B02.45**

Tienen un número de orden de fabricación estampado en cada pieza, desde el cual, en cualquier momento, se puede llegar a la documentación archivada en la Oficina Técnica y así identificar cada característica y elemento de fabricación y control de calidad. Todos los procedimientos de calidad y seguridad, dispuestos por el sr.Bertorello, responsable del dossier técnico y empleado en la sede de OMCR en Via Quarantelli,8 10077 San Maurizio C.se, han sido correctamente ejecutados y esto nos ha permitido el marcaje del símbolo **CE** para garantizar que los siguientes elementos:



- Son conformes a las condiciones indicadas por la directiva Maquinaria 2006/42/CE del 9.6.2006.
- Son objeto de control y verificación, para adecuarse también a las normas UNI, las directivas europeas y las disposiciones italianas sobre seguridad laboral.

*Antes de la utilización de los dispositivos de elevación lateral con bulón leer atentamente el manual de uso y mantenimiento*

*Una utilización impropia o contraria a la descrita en el manual, anula la validez de la presente declaración CE de conformidad y exime a OMCR de cualquier responsabilidad.*

*Este manual de uso y mantenimiento completo conforme a la normativa CE ha sido traducido del italiano, en el caso de cualquier reclamación tiene validez jurídica la versión en italiano.*

**OMCR S.r.l.**  
El representante legal  
**Domenico Zentilin**







Notice d'entretien et d'usage  
avec déclaration **CE** de conformité.

# CHAPE DE MANUTENTION AVEC LA BROCHE



Codes des articles : **B01.35 - B02.45**

## INDEX

1. ÉVALUATION DES RISQUES. ....	51
2. SYMBOLIQUE ET CLASSIFICATION DES AVERTISSEMENTS. ....	51
3. USAGE .....	52
4. MOUVEMENTATION ET STOCKAGE .....	58
5. ENTRETIEN .....	59
DÉCLARATION CE DE CONFORMITÉ .....	60

## 1. ÉVALUATION DES RISQUES







Les contenus des pages suivantes se réfèrent au usage classiques des chapes de manutention et ils peuvent pas prévoir emplois pas-spécifiques. Pour cette raison, chacun utilisateur doit pourvoir une propre évaluation des risques et il doit prendre en compte cette notice comme référence générale en considérant la nécessité de synthèse dans traiter les sujets. C'est à l'utilisateur de définir les procédures d'emploi concernant les opérations à suivre pour le personnel préposé, il doit aussi diffuser les informations et vérifier en le respect. Les chapes de manutention servissent comme crochet pour cordes ou chaînes et ils permettent d'effectuer en sécurité les opérations de: LEVAGE, MOUVEMENTATION, RENVÈREMENT; le matériel, la production et l'essai de tous les chapes de manutention OMCR sont conformes aux requêtes de la Directive **2006/42/CE**; tous les éléments de manutention OMCR viennent vérifiés avec un coefficient d'épreuve statique égal au minimum 1.5, sur tous les matériels viennent effectuées analyses selon l'**UNI EN 10204**, sur échantillons viennent effectuées épreuves à traction conventionnelle conformes au **UNI EN 10002**.

### AVERTISSEMENT

**Avant l'usage des chapes de manutention, lire attentivement la notice d'usage et d'entretien.  
Un usage impropre ou contraire en référence à ceci qu' est écrit dans la notice, décharge l'OMCR de  
quelconque responsabilités concernant la sécurité des sujets cités.**

## 2. SYMBOLIQUE ET CLASSIFICATION DES AVERTISSEMENTS

Dans cette documentation la classification des dangers a été fait en référence aux normes ISO 3864-2, ANSI Z535.6, ANSI Z535.4, comme suit:

 <b>AVERTISSEMENT</b>	Désigne une situation potentiellement dangereuse. Si cette situation dangereuse ne peut pas être évitée, la mort ou des blessures graves (mutilations) peuvent en être la conséquence.
 <b>ATTENTION</b>	Désigne une situation potentiellement dangereuse. Si cette situation dangereuse ne peut pas être évitée, des blessures légères ou minimales peuvent en être la conséquence.
<b>NOTE</b>	Conseils ou autres informations d'une importance particulière.
	Danger générique.
	Risque d'écrasement suite la chute ou le renversement du charge.
	Risque de cisaillement suite la chute ou le renversement du charge.
	Risque des troubles musculo-squelettiques pour la mouvementation manuelle des charges.
	Opérations ou emplois pour un usage interdit.
	Mesures à prendre pour éviter les risques.
	Stationnement ou passage interdit.

### 3. USAGE

#### 3.1

##### ⚠ AVERTISSEMENT



Chaque opérations de levage / mouvementation / renversement doit être exécutées par un personnel qualifié et appropriément instruit; les personnes préposées au levage, mouvementation, renversement doivent utiliser moyens de protection en dotation.

#### 3.2

##### ⚠ AVERTISSEMENT



Avant chaque levage / mouvementation / renversement les personnes préposées doivent choisir l'élingue plus appropriée à garantir une suspension en sécurité avec un correct équilibre du charge. L'effective portée des cordes / chaînes et des accessoires de manutention peut être modifié par un élingue incorrecte. Dans le tableau suivant on peut évaluer la réduction de la portée nominale en fonction de l'angle de l'élingue au but de maintenir constant le facteur de sécurité.

##### NOTE

Pour la définition des élingues symétriques et asymétriques vous devez voir la norme EN818-06: en cas des élingues asymétriques, on considère que le charge à soulever est supporté par seulement deux bras de corde/chaîne.

#### 3.2.1 - LEVAGE

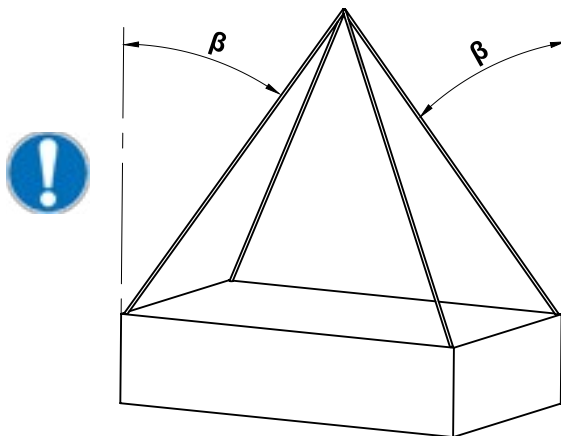

##### EXEMPLE DES ÉLINGUES SYMÉTRIQUES (CONDITION RECOMMANDÉE)

ANGLE	FACTEUR DE RÉDUCTION DE LA PORTÉE DE LA CHAPES
$0^\circ \leq \beta \leq 40^\circ$	1
$40^\circ < \beta \leq 50^\circ$	0.84
$50^\circ < \beta \leq 60^\circ$	0.65

**G** = Barycentre outillage

**β** = Angle des cordes à partir de la verticale

**NOTE:** le levage avec  $\beta > 60^\circ$  il est pas prévu

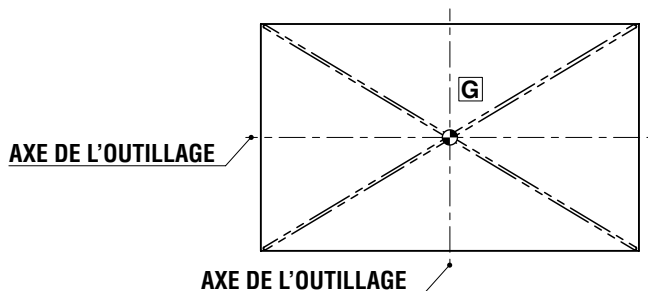

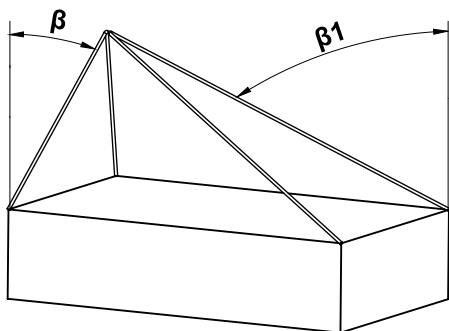

### EXEMPLE DES ÉLINGUES ASYMÉTRIQUES

#### FACTEUR DE RÉDUCTION DE LA PORTÉE DE LA CHAPES

0.5

**G** = Barycentre outillage

$\beta$  = Angle minimal des cordes à partir de la verticale

$\beta_1$  = angle maximal des cordes à partir de la verticale

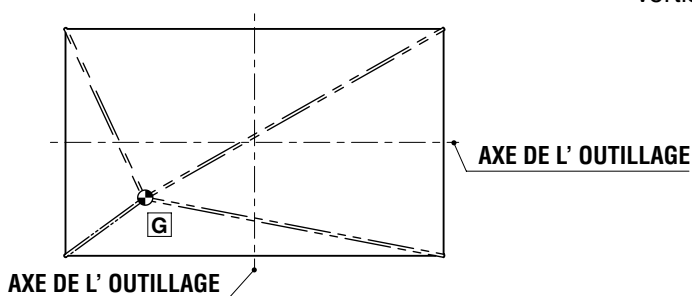

### AVERTISSEMENT

*Le non-respect des prescriptions contenues dans la présente notice peut provoquer la chute ou le renversement du charge.*

### 3.2.2 - RENVERSEMENT

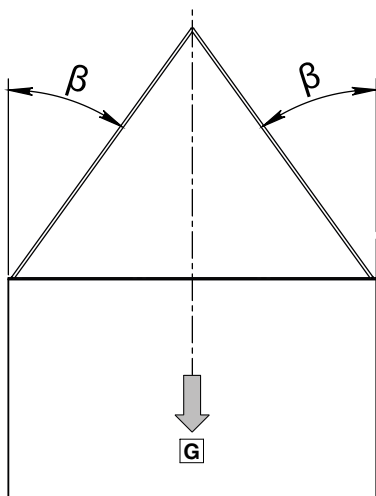

### EXEMPLE DES ÉLINGUES SYMÉTRIQUES (CONDITION RECOMMANDÉE)

ANGLE $\beta$	FACTEUR DE RÉDUCTION DE LA PORTÉE DE LA CHAPES
$0^\circ \leq \beta \leq 40^\circ$	1
$40^\circ < \beta \leq 50^\circ$	0.84
$50^\circ < \beta \leq 60^\circ$	0.65

**G** = Barycentre outillage

$\beta$  = Angle des cordes à partir de la verticale

**NOTE:** le levage avec  $\beta > 60^\circ$  il est pas prévu

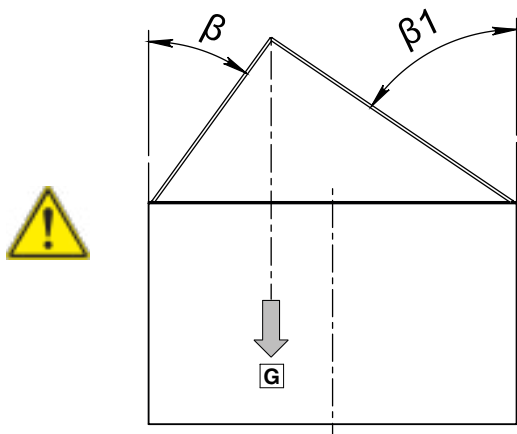

**EXEMPLE DES ÉLINGUES ASYMÉTRIQUES  
( $\beta_1 > \beta$ )**

ANGLE	FACTEUR DE RÉDUCTION DE LA PORTÉE DE LA CHAPES
$\beta < 15^\circ$	0.5
$\beta > 40^\circ$	
$\beta_1 - \beta > 15^\circ$	

**G** = Barycentre outillage

**β** = Angle minimal des cordes à partir de la verticale

**β1** = angle maximal des cordes à partir de la verticale

**⚠ AVERTISSEMENT**

*Le non-respect des prescriptions contenues dans la présente notice peut provoquer la chute ou le renversement du charge.*

**3.2.3**

**⚠ AVERTISSEMENT**



*Le renversement de l'outillage peut être exécuté seulement parallèlement à l'axe de la broche de manutention.*

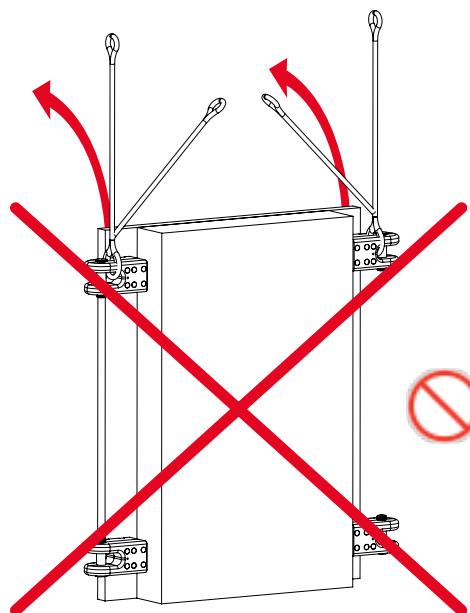
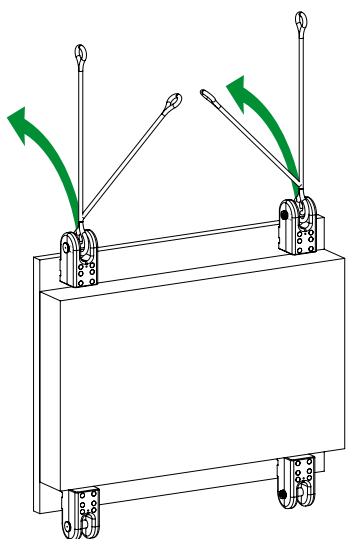

### 3.3

#### **AVVERTISSEMENT**



Au moment de l'opération, vérifier la correcte fermeture des vis; dans le tableau suivant vous trouvez les vis et les couples de fermeture pour le fixage des chapes de manutention; **on conseille l'usage des freinfilets LOCTITE 243 ou rondelles antidesserrage. Garantir formellement la prise minimale filets 1x Ø vis. Exemple: pour vis M36, prise minimale filets 36mm**

LIFTING BRACKET ART. NUM.	NR. SCREWS	SCREWS DIN 912 CL. 8.8	CLAMPING COUPLE [Nm]
B01.35.42500	6	M36x250	2481

#### **AVVERTISSEMENT**

Le non-respect des prescriptions contenues dans la présente notice peut provoquer la chute ou le renversement du charge.

### 3.4

#### **AVVERTISSEMENT**



Les chapes B01.35. doivent être montées sur plaques en acier (qualité minimale Fe510, S355). Les chapes B01.35. doivent être montées avec les clavettes; on conseille l'usage des barrières à éviter l'insertion incorrecte des broches (voir Fig.1)

#### 3.4.1 - APPLICATION SUR LE PLAN

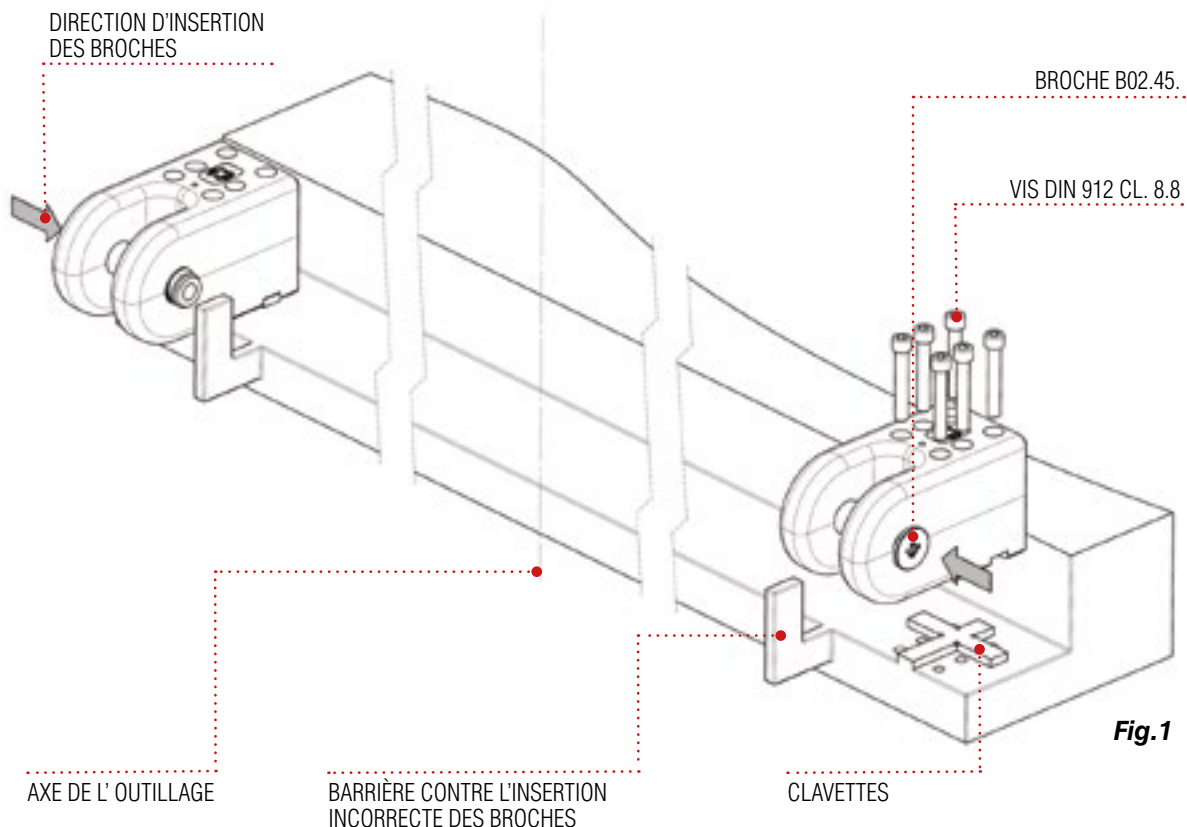

### 3.5

#### ⚠ AVVERTISSEMENT



Avant chaque levage / mouvementation / renversement de l' outillage s'assurer de la correct insertion de la broche du manutention que doit **FORMELLEMENT** être monté avec la **came de sécurité** vers l'axe de la presse: après l'avoir inséré, s'assurer que la **came de sécurité** est pas en axe en respect au trou et elle empêche le désenfilement de la broche; vérifier le mouvement de la **came de sécurité** en vérifiant l'excentricité "E" respect au broche (voir Fig.2)

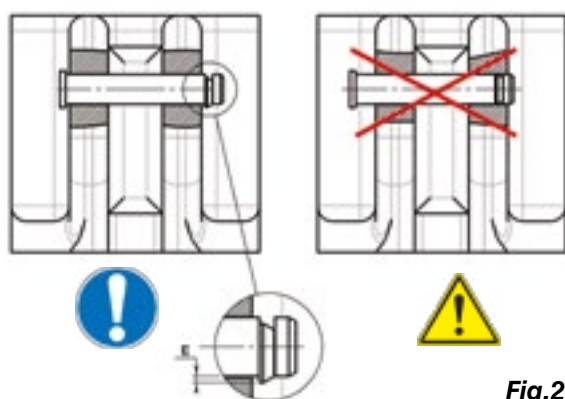

Fig.2

CODE DE LA CHAPE	CODE DE LA BROCHE
B01.35.42500	B02.45.100

### 3.6

#### ⚠ AVVERTISSEMENT



Avant chaque levage / mouvementation / renversement vérifier que la portée des chapes de manutention est conforme au poids de l'outillage la portée maximal, la commande de fabrication, le logo du constructeur et le marque de conformité CE, sont marqués sur la chape de manutention et sur le broche (Fig.3)

**NOTE:** il n'y a pas une correspondance entre les commandes de fabrication des chapes et des broches de manutention.

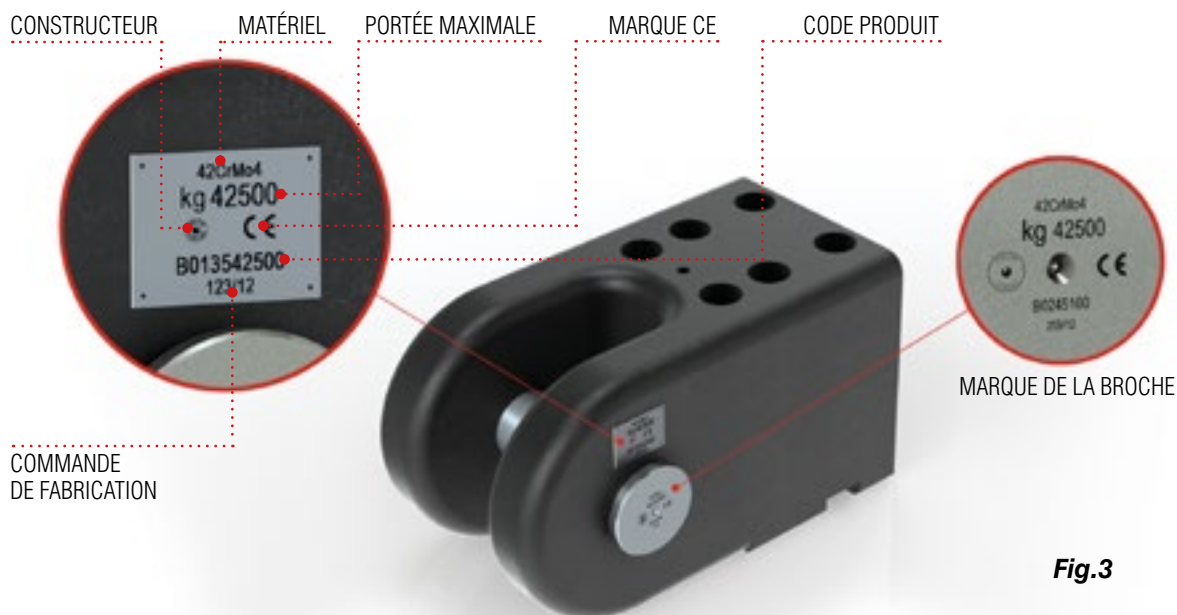

Fig.3



En cas de levage et manipulation la portée de la chapes de manutention doit être au moins égal à **1/2** du poids total de l'outillage ( demi-outillage supérieur + demi-outillage inférieur )

Exemple: poids moule 85.000 kg - portée minimale de la chape:  $85.000 / 2 = 42.500$  kg

En cas de renversement d'un demi-outillage, la portée de la chape de manutention doit être au moins égal à **1/2** du poids du demi-outillage.

Es. Poids demi-outillage 42.500 kg - portée minimal de la chape:  $42.500 / 2 = 21.250$  kg

### 3.7

#### ⚠ AVERTISSEMENT



Avant chaque levage / mouvementation / renversement vérifier que l' élingue choisi (corde / chaîne, crichets, etc.) n'a pas défauts ou malformations qui lui rendent pas en sécurité; dans le cas **eliminer tout de suite les parties défectueuses.**

### 3.8

#### ⚠ AVERTISSEMENT



Pas effectuer levage / mouvementation / renversement avec élingue que forme angles supérieurs à 90° en respect au plan horizontal , en cas contraire on peut se vérifier désenfilement de la broche avec le risque de la chute du charge (voir **Fig.4**).

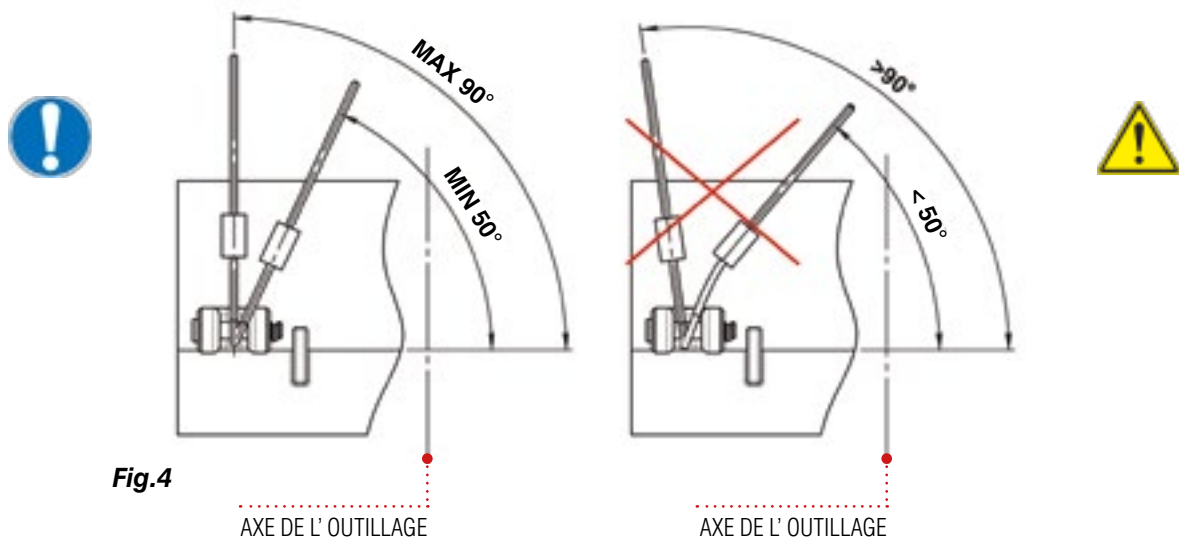

### 3.9

#### ⚠ AVERTISSEMENT



Avant chaque levage / mouvementation / renversement du moule s'assurer que:

- les cordes/chaînes sont assurées dans une correcte façon;
- les cordes/chaînes sont pas en contact avec bords tranchants;
- les cordes/chaînes sont pas accrochées dans les coins de l'outillage.

### 3.10

#### ⚠ AVERTISSEMENT



*Pas s'arrêter ou transiter près du charge pendant les opérations de levage / mouvementation / renversement (voir Fig.5).*



Fig.5

## 4. MOUVEMENTATION ET STOCKAGE

### 4.1

#### ⚠ AVERTISSEMENT



Suite les poids des chapes OMCR cod. B01.35; **les chapes doivent être mouvementées en conformité aux normes en vigueur concernant la mouvementation manuelle des charges.**

CODE DE LA CHAPE	POIDS (kg) <i>y compris de la broiche</i>
B01.24.08000	24
B01.24.12500	50,5

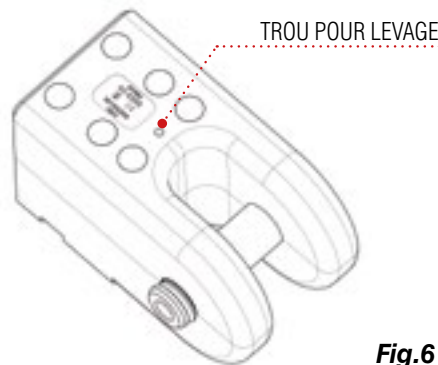

Fig.6

**4.2** Les chapes de manutention doivent être stockées dans lieux loins de l'humidité, si pas utilisées, et protégées de l'oxydation en appliquant huile protectif.

### 4.2.1

#### ⚠ AVERTISSEMENT



**Au moment du montage, nettoyer les surfaces de contact entre la chape de manutention et les plaques porte-outillages.**

*La présence d'huile ou d'impuretés entre la surface d'appui de la chape de manutention et la surface des plaques porte-outillages peut compromettre le fonctionnement correct de la chape de manutention.*

## 5. ENTRETIEN

**5.1** Effectuer tous les 6 mois contrôles visuels pour vérifier la présence des anomalies visibles ou apparition d'oxydation: en cas rétablir ou remplacer les chapes intéressées.

**5.2** Effectuer au moins tous les 12 mois un contrôle de cylindricité pour vérifier eventuelles déformations permanentes (voir **Fig.6**): en cas des erreurs supérieurs à 0.25 mm remplacer les broches intéressés.

**5.3** Effectuer au moins tous les 6 mois contrôles sur la correcte fermeture des vis de fixation selon le tableau mentionné dans la notice.

**5.4** En cas des imprévus effondrements des cordes / chaînes de levage avec un conséquent surcharge sur les broches de manutention, soumettre ceux-ci au contrôle de cylindricité (voir **Fig.6**) pour vérifier eventuelles déformations; en cas des erreurs supérieurs à 0.25 mm remplacer les broches intéressés; remplacer les vis de fixation et vérifier la correcte fermeture selon la tableau mentionné dans la notice.

**5.5** En cas de collisions accidentelles dans le zones d' élingue pendant les opérations de levage / mouvementation / renversement, soumettre ceux-ci au contrôle de cylindricité pour vérifier eventuelles déformations; en cas des erreurs supérieurs à 0.25 mm (voir **Fig.6**) remplacer les broches intéressés; soumettre les chapes de manutention au contrôle visuel pour vérifier eventuelles déformations et si nécessaire remplacer eux; remplacer les vis de fixation et vérifier la correcte fermeture selon la tableau mentionné dans la notice.

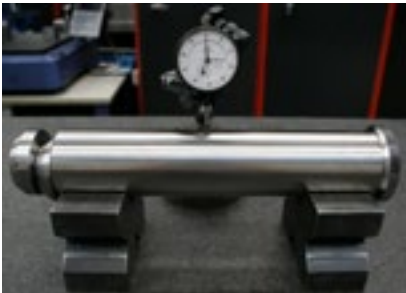

**Fig.6**

# DÉCLARATION CÉ DE CONFORMITÉ

(Directive Machine 2006/42/CE)

L'OMCR S.r.l. avec siège en Via Quarantelli, 8 – 10077 S.Maurizio C.se – (Torino-Italia) dans la personne de son représentant juridique, déclare que, les:

## **CHAPE DE MANUTENTION AVEC LA BROCHE**

### **Codes des articles: B01.35 – B02.45**

Ils ont un nombre de commande de fabrication marqué sur chacun exemplaire dont, en quelconque moment, on peut remonter à la documentation archivée près le Bureau Technique et donc identifier chaque caractéristique et élément de production et essai. Toutes les procédures, de qualité et de sécurité, préparées par Mounsier Bertorello, responsable du dossier technique, en action dans la siège de OMCR,

Via Quarantelli,8 10077 San Maurizio C.se, ont été correctement exécutées et ce-ci a permit l'estampillage du symbole **CÉ** à garantir que ces pièces:



- Sont conformes aux conditions fixées par la Directive Machine 2006/42/CE du 9.6.2006;
- Sont soumis aux contrôles et vérifications, tels à considérer ceux aptes aussi pour le normes UNI harmonisées et nationales, les directives Européennes et les dispositions italiennes sur la sécurité du travail.

*Avant l'usage des chapes de manutention, lire attentivement la notice d'usage et d'entretien. Un usage impropre ou contraire en référence à ceci qu' est écrit dans la notice, révoque la validité de cette présente déclaration CE de conformité et décharge l' OMCR de quelconque responsabilités à propos.*

*Traduction de l'originelle Notice d'Usage et Entretien et de la Déclaration de Conformité. En cas de doutes ou incompréhensions, la version Italienne est décisive.*

**OMCR S.r.l.**  
Le représentant légal  
Domenico Zentilin

